



# THE IMPACT OF AUDIT QUALITY, AUDIT COMMITTEE, AND INTERNAL CONTROL SYSTEMS ON FINANCIAL REPORT QUALITY (IDX FINANCE SECTOR)

DEA VAN SEM\*  
THERESIA DWI HASTUTI

Department of Accounting, Faculty of Economic and Business, Soegijapranata Catholic University  
Jalan Pawiyatan Luhur IV Number 1, Bendan Duwur, Gajahmungkur District, Semarang City,  
Central Java, Indonesia

## Article History:

Received : 2024-05-09

Revised : 2024-05-18

Accepted : 2024-05-26

Published : 2024-07-09

## Corresponding author:

deavanssem22@gmail.com

## Cite this article:

Sem, D. V., & Hastuti, T. D. (2024). The Impact of Audit Quality, Audit Committee, and Internal Control Systems on Financial Report Quality (IDX Finance Sector). *Keunis*, 12(2), 120-133.

## DOI:

10.32497/keunis.v12i2.5507

**Abstract:** *The objective of this study is to examine the impact of audit quality, audit committees, and internal control systems on the quality of financial reporting. The study population consists of financial companies listed on the IDX during the period 2018-2022. Secondary data in the form of annual reports were obtained from the website [www.idx.co.id](http://www.idx.co.id), and data were collected from 230 financial companies using the purposive sampling method. This study employs multiple linear regression analysis with the assistance of SPSS version 25. The findings indicate that the internal control system exerts a positive influence on the quality of financial reports. Nevertheless, neither audit quality nor the audit committee has any impact on the quality of financial reports.*

**Keywords :** Internal Control System, Audit Quality, Audit Committee, Financial Report Quality.

## INTRODUCTION

Financial reports are one of the final products of the accounting process that provide an overview of the financial condition and operational results of an entity. The information contained in the financial report is very vital for various parties, both internal and external to the company. Through financial reports, management can get a clear picture of the company's financial performance, while external parties such as investors, creditors and the government can use this information as a basis for making decisions. To ensure that financial reports are trustworthy and relevant, institutions such as the International Accounting Standards Board (IASB) have developed qualitative standards of financial information that every financial report must meet. These standards cover aspects such as relevance, honesty, comparability, integration, verification and understanding, all of which aim to ensure that the information presented in financial reports is truly useful in decision making (Stevani & Meirini, 2023).

The important role of financial reports is also reflected in their ability as an effective tool in decision making. By meeting qualitative standards for financial information, financial reports can be a reliable guide for interested parties. For example, investors can use the information contained in financial reports to evaluate company performance and make appropriate investment decisions. Likewise, creditors can use financial reports to assess the company's ability to fulfill its obligations (Mardani et al., 2020). Therefore, it is important for every entity to maintain the quality of its financial reports so that they remain relevant and can be trusted by interested parties.

However, to ensure that financial reports are truly reliable, it is not just enough to meet the qualitative standards of financial information. It is also important to consider other factors that can influence the quality of financial reports, such as management integrity in preparing financial reports, transparency in disclosing information, and the effectiveness of the internal control system in identifying and preventing potential errors or fraud in preparing financial reports. By paying attention to these factors, it is hoped that financial reports can become a more effective instrument in supporting appropriate and accurate decision making (Hastuti et al., 2017).

Research on the quality of financial reporting is important because good reporting can maintain transparency and accountability in companies. This research has an impact on individuals and groups such as factors that can cause fraud and helps companies increase transparency so as to produce quality financial reports. Clear and accurate financial reports about company performance help stakeholders make informed decisions. This not only benefits internal management, but also protects shareholder interests by providing accurate and relevant information. In addition, research on audit quality, audit committees, and internal control systems has important implications for the development of regulations and supervisory practices in industry. The main aim of this research is to identify factors that can cause problems in financial reporting, such as fraud. With a deeper understanding of audit quality, it is hoped that audit committees and internal control systems can improve the efficiency and effectiveness of their internal control processes. This will reduce the risk of fraud and errors in financial reporting, and help ensure that audit practices and internal controls comply with audit industry standards and good governance. Thus, this research has broad implications in improving the quality of financial reporting and supervision in companies. (Indaryuni et al., 2021).

Fraud cases related to the preparation of financial reports are still a serious concern, because they can result in poor quality reports. This phenomenon continues to occur in the financial sector, showing the importance of analyzing factors that influence the quality of financial reports, including audit quality, audit committees, and internal control systems. One example of a fraud case that occurred was the manipulation of financial reports carried out by PT Waskita Karya Tbk (WSKT) in 2023. Quoted from (Banjarnahor., 2023), this case emerged because the company's financial reports did not match the actual conditions in the field, where despite reporting profits every year, there is no significant increase in cash flow. Apart from that, PT Waskita Karya Tbk (WSKT) is also recorded as having a lot of debt to creditors and the vendors it uses. Financial report data shows that in 2016, PT Waskita Karya Tbk (WSKT) net profit was recorded at 1.71 trillion with cash flow of minus 9.55 trillion. In 2017, net profit increased to 3.88 trillion, but cash flow still showed poor performance at minus 19.24 trillion. A similar thing happened in the following years, where net profit was recorded to increase but cash flow remained negative. Apart from that, PT Waskita Karya Tbk (WSKT) also has quite large bank loans, reaching 101.59 trillion. This case is currently under investigation by the Financial and Development Supervisory Agency (BPKP), which may also involve the Public Accounting Firm which audits the financial statements of PT Waskita Karya Tbk (WSKT). Thus, this case illustrates the significance of rigorous oversight of the preparation of financial reports to prevent fraud and maintain the integrity of the company's financial information (Mardani et al., 2020).

The initial factor believed to impact the quality of financial reports is audit quality. In the context of agency theory, it is posited that the principal delegates the task of administering the firm to managers, who in turn tend to select the big four public accounting firm. This is because the big four public accounting firm adheres to international standards and enjoys a positive reputation among clients. Additionally, the big four public accounting firm possesses superior skills, extensive experience, and a commitment to staying abreast of developments, including the use of advanced technologies, which collectively serve to mitigate the risk of fraud in the auditing process. This situation can trigger company behavior to make financial reports transparently in accordance with good corporate governance. Even though the costs of the big four public accounting firms are more expensive, transparency in financial reports is of higher quality. Furthermore, big four public accounting firms are preferred by companies because in the process of auditing financial reports they tend to have a high degree of independence, are more effective and trustworthy so they can produce high quality financial reports. Therefore, big four public accounting firms are more reliable than non-big four public accounting firms. Based on research conducted by (Ermawati et al., 2020; Permatalia & Haryono, 2021; Rezra, 2022) it is stated that audit quality has a positive and significant influence on the quality of financial reports, because big four public accounting firms are more reliable than non-big public accounting firms. four. Meanwhile, research conducted by (Indaryuni et al., 2021) states that audit quality

has no effect on the quality of financial reports, because there is no difference between big four and non-big four public accounting firms.

The second presumed factor affecting the quality of financial reports is that of the audit committee. The audit committee is an oversight body that ensures the company's accounting and financial reporting processes are functioning properly and with transparency. The audit committee exerts an influence on the quality of financial reports due to its responsibility of monitoring and evaluating the performance of internal auditors, thereby facilitating their independence in examining financial reports and producing quality financial reports. Audit committees that have a background in accounting tend to understand the processes in making financial reports better than audit committees that do not have a background in accounting, because audit committees that have a background in accounting have better accounting expertise so they can minimize the occurrence of irregularities and produce higher quality financial reports. This is in line with research conducted by (Indaryuni et al., 2021) which states that the audit committee has a positive influence on the quality of financial reports, because the effectiveness of the audit committee in carrying out audits reliably can influence the quality of financial reports. Meanwhile, research conducted by (Inawati et al., 2021) states that audit committees have a negative effect on the quality of financial reports, because the more audit committees that have competence, the more opportunities they have to benefit themselves. Meanwhile research conducted by (Ermawati et al., 2020) states that the audit committee does not have a significant effect on the quality of financial reports, because the formation of an audit committee is only a formality in company regulations.

The third factor that is believed to affect the quality of financial reports is the internal control system. An internal control system is a procedure devised to protect assets and to ensure the reliability and accuracy of financial reports. The internal control system impacts the quality of financial reports because it prevents and detects fraud, misappropriation, and protects stakeholders while ensuring transparency in the financial reporting process, thus producing quality financial reports. The internal control system serves to prevent fraud, such as task segregation. A well-designed internal control system can enhance the quality of financial reports and boost investor confidence in the company's future, thereby assisting investors in making informed decisions. Research conducted by (Pratiwi & Aufa, 2023) indicates that SPI has a positive impact on the quality of financial reports. This is because the implementation of a robust internal control system can influence the quality of financial reports, thereby reducing the likelihood of fraud. In contrast, research conducted by (Sitorus et al., 2019) indicates that SPI does not significantly impact the quality of financial reports, as the internal control system is not utilized effectively.

Based on the results of this research, it can be concluded that the results of research regarding audit quality, audit committees and internal control systems are still inconsistent so researchers want to re-examine research regarding the influence of audit quality, audit committees and internal control systems on the quality of financial reports. Furthermore, there is a gap phenomenon and gap research regarding the influence of audit quality, audit committees, and internal control systems on the quality of financial reports. This research provides a new contribution by exploring the factors that influence the quality of financial reports in Indonesia, especially in the context of fraud cases. Previous research has not specifically examined the implications of audit quality, audit committees, and internal control systems on the quality of financial reports in Indonesia. This is an important topic given the country's unique characteristics and regulations. Previous research has only examined the local government sector and not companies listed on IDX. Moreover, researchers have identified an existing research gap. Previous research, as evidenced by the studies of (Andriani et al., 2019 & Sitorus et al., 2019), has not yet explored the influence of internal control systems on the quality of financial reports to a sufficient depth and has not mentioned implications of internal control systems that can affect the quality of financial reports. Therefore, researchers incorporated the internal control system (ICS) variable in order to illustrate the role of ICS in the detection, identification, prevention, and management of fraud. Fraud can result in the degradation of financial reports, which in turn can damage investor confidence. ICS can also ensure the compliance of finance companies with relevant legislation and regulations, thus enhancing the credibility of financial reports. (Deumes & Knechel, 2008; Hastuti et al., 2016; Hastuti et al., 2017). The present research examines the contribution of the primary components of the internal control system, namely the control environment, risk assessment, control activities, information and communication, and monitoring, to the quality of financial reports within the IDX financial sector. Furthermore, in contrast to previous research which mostly researched manufacturing sector companies

and local governments, researchers used financial sector companies listed on IDX because they wanted to know the condition of the quality of financial reports in which there is financial innovation and how companies identify and manage risks to improve performance. and financial sector stability, knowing the development of financial technology in the financial sector, and focusing more on the finance sector, so this research has novelty because it focuses more on the internal control system for the quality of financial reports in the IDX finance sector. The results of this research can provide new insights and a deeper understanding of the factors that influence the quality of financial reports in Indonesia, especially in efforts to prevent fraud cases which still frequently occur.

## **THEORETICAL FRAMEWORK AND HYPOTHESES**

### **Agency Theory**

Agency theory explains the relationship between audit quality, audit committees, and internal controls. An agency relationship is a contract in which one or more principals (owners) involve another party (agent) in providing services, according to (Jensen & Meckling 1976). The owners are interested in delegating some decision-making authority to the agents. Agency theory assumes that the principal aims to maximize his profits, while the agent aims to maximize his economic and psychological needs. Conflicts of interest often arise due to misaligned interests between the parties. This situation is often called "moral hazard". In this case, shareholders are not aware of the risks associated with management's actions, which of course creates information asymmetry among shareholders (Rezra, 2022).

Pratiwi and Aufa (2023) theory of information asymmetry arises when managers possess more internal information and knowledge of the company's future prospects than shareholders and other stakeholders, who have differing goals. Such situations can be exploited by certain parties to commit fraud. Due to the presence of information asymmetry, an independent party may be required to audit the financial reports prepared by company management.

It is based on agency theory and information asymmetry and was chosen as the primary theory for its consistency in describing issues related to financial reporting quality. This is an interesting development because this study applies concepts from agency theory to resolve conflicts using attachment and monitoring mechanisms. This approach includes the implementation of a senior management remuneration policy as part of the engagement agreement. In the area of regulation, the concept now also includes regulatory measures implemented by internal and external parties. According to (Permatalia & Haryono 2021), internal oversight arrangements are implemented through the role of the board of directors (two tiers) or non-executive directors (single tier). An audit committee and internal auditors are responsible for the independent monitoring and evaluation of the company's performance. At the same time, external oversight arrangements include independent auditors, the role of the media, and government regulation, which play a role in ensuring the transparency and accountability of companies' financial reporting. The role played by audit committees and external auditors in overcoming information asymmetries, which can have a detrimental effect on the interests of shareholders, is of great importance in maintaining the integrity of a company's financial reporting. The extent to which information is disclosed to shareholders and other stakeholders is closely related to the quality of financial reporting.

In this case, agency theory emphasizes the importance of transparency and adequate disclosure to reduce potential agency conflicts between managers and shareholders. Agency theory includes the concepts of incentives and contracts. Poor quality or manipulative financial reports can lead to agency conflicts, where managers may have incentives to present company performance as better than it actually is. Therefore, high-quality financial reports help reduce these kinds of incentives and ensure that managers do not profit excessively. Apart from that, government regulations and supervision can also help improve the quality of financial reporting. This can reduce the potential for agency conflicts and give shareholders confidence that financial reports comply with applicable standards and regulations.

Agency theory is therefore important in understanding the importance of financial reporting quality in managing agency conflicts between shareholders and corporate managers. High-quality financial reporting helps reduce information asymmetry and supports shareholder interests.

### **The impact audit quality on the quality financial reports**

R. Hayes et al., (2015) contends that a high level of education and training are required to perform an effective audit of financial statements according to the applicable reporting framework, International Financial Reporting Standards (IFRS). This highlights the impact of audit quality on the confidence of internal and external parties in the quality of financial reports. According to agency theory, conflicts of interest, known as moral hazard, can arise due to personal interests of both the principal and the agent. Moral hazard arises from actions taken by the agent that are not known to the principal, resulting in information asymmetry. As managers are agents entrusted by the principal to manage the firm, they tend to select an audit firm with a high reputation and a high degree of independence to audit the firm's financial statements. The Big Four auditing firms are considered more efficient and reliable in preparing audit reports that ensure the fairness of a company's financial statements. This is due to their ability to complete audit work efficiently and effectively within the specified time, as well as their broad experience in handling various types of financial reporting cases. An independent party is necessary to audit financial reports and produce high-quality financial reports. Studies by (Abbott et al., 2015; Fauzi & Wardono, 2022; Imar & Effendi, 2019; Kamolsakulchai, 2015; Sepasi et al., 2017; Suryana & Pitaloka, 2019) indicate that audit quality is positively related to financial report quality. Therefore, companies that use a Big Four audit firm have greater confidence in audit quality. Based on this, we can formulate the following hypothesis:

H1: Audit quality positively affects the quality of financial reports.

### **The influence of the Audit Committee on the quality of financial reports**

The company's directors establish an audit committee comprising members appointed from outside the company. The audit committee aids in overseeing the financial reporting process and enhances the autonomy of internal and external audits. Audit committees in the internal sector monitor internal audits, evaluate the effectiveness of the internal control system, supervise auditor performance, communicate regularly with the board of directors regarding significant audit issues, and investigate issues related to fraud. The external committee selects external auditors, monitors their performance, and evaluates financial reports. The audit committee's primary responsibility is to help the board oversee management's financial reporting process, thereby increasing confidence in the financial statements. Committees facilitate formal communication channels that allow interaction between the board, management, external auditors, and internal auditors. This formal communication is important to ensure an effective internal and external audit process (R. Hayes et al., 2015).

Agency theory uses authoritative and supervisory approaches to conflict resolution. A binding agreement arises when the binding party acting as agent (usually the party receiving services) has more information than the binding party (the principal). Management agents are responsible for overseeing company operations to prevent fraud. Oversight is conducted by both internal parties, such as audit committees and internal auditors, and external parties, such as external auditors, media, and government. Therefore, the audit committee plays an important role as an oversight body for financial reporting because in this theory it accounts for the differences in interests between agents and clients so that information asymmetry does not occur. Based on the above description, the audit committee is the bridge between the board of directors, management, external auditors and internal auditors and management to solve company problems.

According to Alzeban, (2020); Indaryuni et al, (2021); Kamolsakulchai, (2015) found that audit committees have a positive impact on financial reporting quality. The purpose of an audit committee is to assist the board in its oversight of the auditors and their independence from management. In order to ensure the transparency, accountability and reliability of financial reporting, the audit committee plays a crucial role. Therefore, the following hypothesis can be formulated:

H2: Audit committee has a positive impact on financial reporting quality

### **Effect of implementing the Internal Control System on the quality financial reports**

Hayes et al., (2015) defines internal control as the process used to safeguard a company's aspects, such as financial reports, from manipulation or duplication. A robust internal control system can minimize deviations, errors, and mistakes in financial report preparation. Agency theory posits that a conflict of interest arises between principals and agents. Shareholders (principals) endeavor to guarantee that management (agents) acts in their best interests. Internal controls—such as the internal audit process—can help to diminish the disparity of information between management and shareholders by providing an assessment and validation of the information

utilized in the formulation of financial reports. The internal control system serves as a tool that assists shareholders in observing and regulating management activities, thus ensuring responsibility and transparency.

Pratiwi and Aufa (2023) carried out a study which shows that there is a positive correlation between the quality of the financial reports and the evaluation of the internal control system. A good internal control system instills confidence in investors regarding the company's future. Implementing an internal control system can reduce errors, inaccuracies, and irregularities in financial report preparation. This information is crucial for investors when making decisions. The findings of the study conducted by (Rokhlinasari & Hidayat 2016) demonstrate that an effective internal control system is positively associated with the quality of financial reporting. This suggests that the system provides management with the necessary tools to regulate financial reports. The following hypothesis can be formulated:

H3 : The quality of financial reports is positively affected by the Internal Control System.

## RESEARCH METHODS

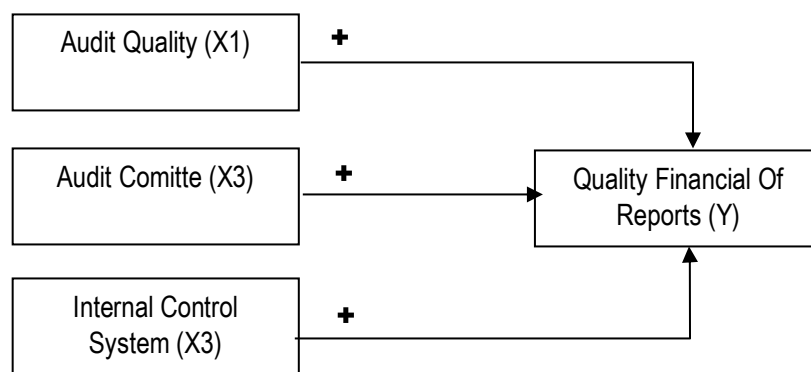

Figure 1. Research Model

### Sample Determination and Data Collection Techniques

The study population comprised 450 data points from finance companies registered on the IDX between 2018 and 2022. Secondary data was obtained from the website [www.idx.co.id](http://www.idx.co.id). The purposive sampling technique was used for sample selection, with the following criteria: (1) Financial companies registered on IDX between 2018 and 2022, and (2) Financial companies listed on IDX that published complete annual reports for 5 years during the 2018-2022 period. (3) This study focuses on financial companies registered on IDX that have complete data available for research during the 2018-2022 period. There are 220 companies registered on IDX that did not publish annual reports during this period, and 230 financial companies registered on IDX that have complete data available for research during the same period.

### Variable Measurement

#### Audit Quality

Accounting firms that are part of the big four and non-big four groups are distinguished by the quality of their auditors. To measure audit quality, financial companies that use big four audit firms are scored 1, and non-big four audit firms are scored 0. Both big four and non-big four audit firms are scored 1 or 0, depending on their use of big four audit firms. (Zahroh & Hermanto, 2018)

#### Audit Committee

The audit committee is a supervisory body that has the responsibility to help auditors maintain independence. The measurements used in the audit committee variable are (Inawati et al., 2021):

$$\frac{\text{number of members who are competent } \in \text{ the field } \frac{\text{auditing}}{\text{accountancy}}}{\text{total number of audit committee members}} \quad (1)$$

#### Internal Control System

Corporate governance refers to the processes, principles, and values that guide the effective and efficient achievement of organizational goals. The quality of corporate governance can be evaluated through the internal

control elements included in the annual financial report. These elements comprise the internal control system are: (Deumes & Knechel, 2008; Hastuti et al., 2016; Hastuti et al., 2017) :

1. If the annual report indicates that the audit committee has found internal control within the company, it is assigned a score of 1.
2. If the annual financial report discloses the management board's goals for the company's internal control, it is assigned a score of 1.
3. Management's acknowledgement of its responsibility for internal control in the annual report is a score of 1.
4. The effectiveness score is 1 only if the board of directors provides an opinion on the internal control's effectiveness.
5. If the internal audit is described in the financial reports, it will receive a score of 1.
6. Additionally, if the financial report discloses risk management activities, it will receive a score of 1.

### Quality of Financial Reports

The quality of financial reports can be seen by ROE, where ROE influences profits and the measurement scale used is the nominal scale. as for the measurements used in the financial report quality variable (Imar & Effendi, 2019):

$$ROE = \frac{profit}{equity} \quad (2)$$

### Data Analysis Technique

#### Descriptive Statistics

According to Ghozali (2018), Descriptive statistics aims to provide an overview and examine the data used in research such as maximum, minimum and average. The sample in this research consists of finance companies listed on IDX during the 2018-2022 period.

#### Classic Assumption Test

Ghozali (2018) states that before using linear regression analysis, it is necessary to conduct a classical assumption test, which includes tests for multicollinearity, residual normality, autocorrelation, and heteroscedasticity. If these assumptions are violated, the results of regression analysis and tests such as t-test and F-test are invalid.

##### 1. Normality test

A normality test can be employed to assess the distributional characteristics of data sets. As elucidated by (Ghozali, 2018), a variety of approaches can be adopted in this regard, including the use of graphic statistics. In the case that the points align with the diagonal line, the data is deemed to exhibit a normal distribution. Conversely, if the points deviate from this line, the data is deemed to exhibit non-normal distribution.

##### 2. Multicollinearity test

In order to ascertain whether the independent variables in a model are correlated with one another, it is necessary to perform a multicollinearity test. A number of criteria can be employed to determine whether multicollinearity exists. One such criterion is that if the VIF value is less than 10, then multicollinearity is not present. Conversely, if the VIF value exceeds 10, then multicollinearity is present (Ghozali, 2018).

##### 3. Autocorrelation Test

To find out whether or not there is autocorrelation between variables in the time change prediction model, you can use statistical tests. (Sunyoto, 2016) outlines several criteria for decision making in the Durbin Watson test. A value of the Durbin-Watson (DW) test less than or equal to 2 indicates the presence of positive autocorrelation, while values greater than 2 or less than -2 indicate the absence of autocorrelation. Negative autocorrelation is indicated by values greater than or equal to 2 and less than -2.

##### 4. Heteroscedasticity Test

A heteroscedasticity test is conducted to ascertain whether there is a variance in the residuals ( $\epsilon$ ). This test involves regressing the absolute value of the residual ( $|\epsilon|$ ) on all independent variables. According

to (Ghozali, 2018), if the significance is greater than 0.05, then there is no heteroskedasticity. Heteroscedasticity is present if the significance is  $< 0.05$ .

### **Multiple linear regression**

The objective of this study is to analyse the relationship between dependent and independent variables. To accomplish this, we employ multiple linear regression. In this study, we utilise SPSS for the purpose of testing whether the independent variables of audit quality, audit committee composition, and internal control system design can influence the quality of the financial reporting produced by the entity in question. The results will be presented in tabular form, accompanied by a description of the model used in multiple linear regression :

$$Y = a + b_1 X_1 + b_2 X_2 + b_3 X_3 + \varepsilon \quad (3)$$

with

Y: quality financial reports

a : Constant

b1, b2, b3 : regression parameters

X1: audit quality

X2 : audit committee

X3: internal control system

$\varepsilon$  : residual (error)

### **Hypothesis Testing**

The model is said to be significant if it has been tested simultaneously and partially. The significance test can be carried out as follows:

1. F Test or Model Fit Test (Goodness of Fit Models)

To assess the viability of the research model, the F test can be employed. (Ghozali, 2018) delineates several criteria for interpreting the F test results. When the significance level is less than 0.05, the F-test is deemed significant. Conversely, when the significance level is greater than 0.05, the F-test is not considered significant.

2. T test

In order to ascertain whether the independent variable exerts a significant influence on the dependent variable, a T-test can be employed. The T-test is conducted in accordance with several criteria. If the significance level (sig) is greater than 0.05, it can be concluded that the independent variable has no influence on the dependent variable. If the significance level is less than 0.05, it can be concluded that the independent variable exerts an influence on the dependent variable.

3. Coefficient of Determination ( $R^2$ )

This test determines how much an independent variable affects a dependent variable. A good test is indicated by an  $R^2$  value of 1, while a bad test is indicated by an  $R^2$  value close to 0.

## **RESULTS AND DISCUSSION**

### **Descriptive Statistics**

Based on table 1 shows that the quality of financial reports (Y) has an average value of 4.08 with a maximum value of 13.01 obtained from the Bank Woori Saudara Indonesia Tbk (SDRA) company and a minimum value of -3.71 obtained from the Tania Services Insurance company Tbk. (ASJT) because in 2020 there was a Covid-19 case which hampered the company in carrying out operational activities, thus having a negative impact on the company's finances. The audit quality (X1) of the company has an average score of 39%. The maximum score of 1 indicates that the company was audited by 90 Big Four Audit Firm companies, while the minimum score of 0 indicates that the company was audited by 140 Non Big Four Audit Firm companies. The average audit committee (X2) score for finance companies registered on the IDX with an accounting educational background is 35%, with a maximum score of 67%. This suggests that almost all members of the company's audit committee have an accounting educational background. The minimum score is 0%, indicating that none of the finance company audit committee members have an accounting background. The average Internal Control System score for finance companies listed on the IDX that use Internal Control System elements is 5.74, with a maximum score of 6 indicating that almost all companies use Internal Control System elements. The minimum score is 0, indicating that none of



the companies use Internal Control System elements. The average Internal Control System (X3) score for finance companies listed on the IDX that use Internal Control System elements is 5.74, with a maximum score of 6 indicating that almost all companies use Internal Control System elements. The minimum score is 0, indicating that none of the companies use Internal Control System elements.

**Table 1. Descriptive statistics**

	N	Minimum	Maximum	Mean	Std. Deviation
ROE	230	-3.71	13.01	4.08	3.83
Audit Quality	230	0.00	1.00	0.39	0.49
Audit Committee	230	0.00	0.67	0.35	0.14
Internal Control System	230	0.00	6.00	5.74	1.23

Source: *Output IBM SPSS 25 (Data processing, 2023)*

**Classic Assumption Test**

Based on the Figure 2, the data distribution appears to be linear, indicating that the normality requirements are met.

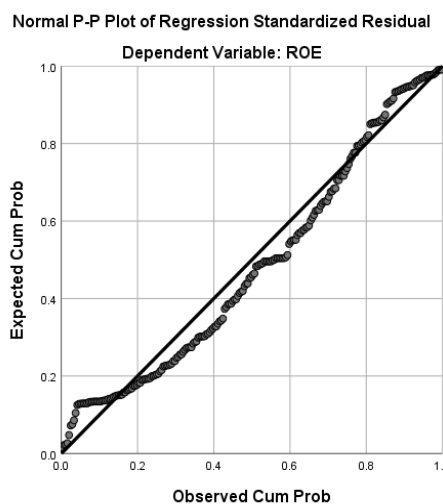

Source: *Output IBM SPSS 25*

Figure 2. Normality Test Graph

Table 2 shows that each independent variable has a tolerance greater than 0.01 and a VIF less than 10. These results are an indication that the regression model is free of multicollinearity. The Durbin-Watson (DW) value is 1.020. Therefore, it can be concluded that the data does not exhibit autocorrelation since the DW value falls between -2 and +2 ( $-2 < DW < +2$ ) (Sunyoto, 2016). The Spearman Rank Correlation method was used to test the research. The results indicate that each independent variable (audit quality, audit committee, Internal Control System) has a significance value of  $> 0.05$ , meaning that they are suitable for predicting the value of financial report quality. The data does not contain heteroscedasticity.

**Table 2. Classic Assumption Test**

Variable	Multicollinearity VIF <10	Autocorrelation (Durbin Watson) -2 and +2	Heteroscedasticity Sig >0.05
<b>Variable Dependen (ROE)</b>			
Audit Quality	1.11	1.02	0.96
Audit Committee	1.19		0.27
Internal Control System	1.10		0.53

Source: *Output IBM SPSS 25*

**Hypothesis Testing**

Table 3 demonstrates a statistically significant effect, as indicated by an F value of 4.169 and a p-value of 0.007, which is less than 0.05. The R<sup>2</sup> value of 0.052 indicates that the independent variable exerts a minimal impact on the dependent variable. The audit quality variable, audit committee, and internal control system collectively contribute 5.2% to the financial report quality variable. Conversely, the remaining 94.8% was influenced by variables not included in the study.

**Table 3. Model Feasibility Test (Goodness of Fit Models), Determination Coefficient Test (R<sup>2</sup>), and Multiple linear regression**

Model	Variable	Unstandardized Coefficients		Standardized Coefficients		Hypothetical Decisions	
		B	Std.Error	Beta	t	Sig.	
1	Intercept	.039					
	Audit Quality	-.194	.535	-.025	-.362	.718	H1 Rejected
	Audit Committee	-.235	1.981	-.008	-.118	.906	H2 Rejected
	Internal Control System	.731	.212	.234	3.440	.001	H3 Accepted
F	4,169						
R	.229						
R-square	.052						
Adj. R-square	.040						

Linear regression equation:

$$\hat{Y} = a + b_1 X_1 + b_2 X_2 + b_3 X_3$$

$$Y = 0.039 - 0.194X_1 - 0.235X_2 + 0.731X_3$$

Source: *Output IBM SPSS 25*

## DISCUSSION

### The impact quality of audit on quality financial of reports

According to the SPSS results, it shows that the T count is -0.362 < T Table is 1.970 and has a significance level of 0.718 > 0.05 so that audit quality has no influence on the quality of financial reports, so the first hypothesis is rejected. These results contradict agency theory which states that ties between owners and suppliers can give rise to information asymmetry, where suppliers have more knowledge than owners. Agency theory also states that information asymmetry can create opportunities for suppliers to act without proper oversight. If oversight of suppliers is inadequate, auditors may fail to detect questionable accounting practices or manipulation of financial statements. There is no difference between audit firms that collaborate with Big Four and non-Big Four firms in auditing company financial statements. All auditors who review financial reports are required to use Public Accountant Professional Standards. Failure to identify information manipulated by suppliers is caused by poor quality auditors. This reflects that the financial reports do not have accurate results related to the company's performance and financial position. This study aligns with the research conducted by (Indaryuni et al., 2021), which suggests that audit quality does not affect the quality of financial reporting.

### The influence on the Audit Committee on quality financial of reports

Based on the SPSS results, it shows that the calculated T value is -0.118 < T Table is 1.970 and the significance level is 0.906 > 0.05 so that the audit committee has no influence on the quality of financial reports, so the second hypothesis is rejected. These findings challenge agency theory, which posits that relationships between owners and suppliers can lead to information asymmetry due to suppliers possessing more knowledge than owners. The research indicates that the audit committee has no impact on the quality of financial reports. This situation may arise when the audit committee lacks comprehensive information and knowledge about the audited company. Events like this can limit the effectiveness of the audit committee in ensuring the quality of financial reports. One causal factor is the low percentage of audit committee members in the sample companies, which is only 35%. This suggests that many audit committee members lack a background in accounting and may not be familiar with current accounting provisions and procedures. Many companies form audit committees only to comply with regulations, such as Regulation No. IX.1.5, which outlines procedures for forming and implementing guidelines for audit committee work. This finding is in line with the research by (Ermawati et al., 2020), which suggests that the audit committee does not have an impact on the quality of the financial reports.

### Effect implementing the Internal Control System on the quality financial of reports

Based on the SPSS results, the calculated T value of 3.440 is greater than the T Table of 1.970, and the significance level of 0.001 is less than 0.05. Therefore, it can be concluded that the internal control system has a positive influence on the quality of financial reports, and the third hypothesis is accepted. These findings are consistent with agency theory, suggesting that strong internal controls are an indicator of high quality financial reporting. This system inspires investor confidence in the company's future and attracts new investors, while also reducing errors in financial reporting and ensuring the quality of financial reports. By providing necessary information, the internal control system helps investors make informed decisions. This finding is consistent with previous studies conducted by (Andriani et al., 2019; Pratiwi & Aufa, 2023; Sihite & Holiawati, 2017) who found that internal control structures have a positive impact on financial reporting quality.

### CONCLUSION

Transparency and accountability are very important to produce quality financial reports in a company. This research aims to determine the impact of audit quality, audit committee and internal control system on the quality of financial reports in finance companies listed on the IDX. The results of the analysis show that audit quality has no effect on the quality of financial reports. This is supported by the potential for information asymmetry which proves that the accuracy of financial reports is not impacted by auditor supervision. Furthermore, this research also shows that the audit committee has no effect on the quality of financial reports, this is due to the lack of comprehensive information and knowledge between the audit committee and the company being audited. Furthermore, the results of this research found that the internal control system has a positive impact on the quality of financial reports. The limitation of this research is that not all financial companies are open about their financial reports. Apart from that, there are also several company financial reports that are not published according to a certain period. Furthermore, this research only uses independent variables such as audit quality, audit committee, and internal control system and only uses research objects in the financial sector listed on IDX for the 2018-2023 period. So that suggestions for further research are obtained, namely adding other variables such as management integrity, because company integrity is the main key to producing good financial reports and superior audit results. Thus, this can strengthen the transparency and accuracy of financial report information, and the relationship between management in a company and auditors will run more efficiently and effectively. Apart from that, future researchers can use other research objects and use the latest year period.

### REFERENCES

- Abbott, L. J., Daugherty, B., Parker, S., & Peters, G. F. (2015). Internal Audit Quality and Financial Reporting Quality: The Joint Importance of Independence and Competence. *Journal of Accounting Research*, 54(1), 3–40. <https://doi.org/https://doi.org/10.1111/1475-679X.12099>
- Andriani, P., Suarsa, A., & Yuniati. (2019). Semarang: Sain Ekonomi Manajemen & Akuntansi Rivi Pengaruh Pengendalian Internal Terhadap Kualitas Laporan Keuangan pada PDAM Tirtawening Kota Bandung. *Sain Ekonomi Manajemen & Akuntansi Rivi*, 1(3), 26–41.
- Banjarnahor., D. (2023, June 16). *Diduga Manipulasi, Ini Keanehan Laporan Keuangan Waskita*. <https://www.bloombergtchnoz.com/detail-news/8588/diduga-manipulasi-ini-keanehan-laporan-keuangan-waskita-karya>
- Deumes, R., & Knechel, W. R. (2008). Economic incentives for voluntary reporting on internal risk management and control systems. *Auditing: A Journal of Practice & Theory*, 27(1), 35–66. <https://doi.org/10.2308/aud.2008.27.1.35>
- Ermawati, L., Yulistia, D., & Arramadani, N. N. (2020). Pengaruh Kualitas Audit dan Komite Audit Terhadap Kualitas Pelaporan Keuangan Perusahaan yang Terdaftar di Jakarta Islamic Index (JII). *JURNAL Akuntansi & Keuangan*, 11(1), 92–111. <https://doi.org/http://dx.doi.org/10.36448/jak.v11i1.1406>
- Fauzi, E., & Wardono, D. U. (2022). Peran Internal Audit Atas Kualitas Laporan Keuangan pada Perusahaan. *Jurnal Riset Pendidikan Ekonomi*, 7(1), 52–61. <https://doi.org/https://doi.org/10.21067/jrpe.v7i1.6277>

- Ghozali, I. (2018). *Aplikasi analisis multivariate dengan program IBM SPSS 25*. Badan Penerbit Universitas Diponegoro.
- Hastuti, T. D., Ghozali, I., & Yuyetta, E. N. (2016). International Journal of Economics and Financial Issues The Effect of International Financial Reporting Standars on the Real Earnings Management and Internal Control Structure as a Moderating Variable. *International Journal of Economics and Financial Issues*, 6(4), 1807–1814. <https://www.econjournals.com/index.php/ijefi/article/view/2964/pdf>
- Hastuti, T. D., Ghozali, I., & Yuyetta, E. N. A. (2017). The Effect of Company Life Cycles on The Accruals Earnings Management With Internal Control System as Moderating Variable. *Polish Journal of Management Studies*, 15(1), 66–75. <https://doi.org/10.17512/pjms.2017.15.1.07>
- Hayes, R., Philip, W., & Hans, G. (2015). *Principles of auditing : an introduction to international standards on auditing*.
- Imar, M. V., & Effendi, D. (2019). Pengaruh Kualitas Auditor dan Opini Audit Terhadap Kualitas Laporan Keuangan pada Perusahaan Manufaktur yang Terdaftar di BEI Tahun 2013-2017. *Jurnal Ilmu Dan Riset Akuntansi*, 8(10), 1–15. <http://jurnal mahasiswa.stiesia.ac.id/index.php/jira/article/view/2655/2664>
- Inawati, W. A., Muslih, M., & Kurnia. (2021). Pengaruh Kompetensi Komite Audit, Kepemilikan Manajemen dan Ukuran Dewan Komisaris Terhadap Kualitas Laporan Keuangan. *Jurnal Bisnis dan Akuntansi*, 23(1), 121–132. <https://doi.org/https://doi.org/10.34208/jba.v23i1.858>
- Indaryuni, D., Andriani, B. F., & Sucipto, S. (2021). Pengaruh Kualitas Audit, Komite Audit dan Ukuran Perusahaan terhadap Kualitas Laporan Keuangan (Studi Pada Perusahaan Yang Terdaftar di JII70 Periode 2018-2020). *J-ISACC Journal of Islamic Accounting Competency*, 1(1), 45–58. <https://e-journal.lp2m.uinjambi.ac.id/ojp/index.php/jisacc/article/view/924>
- Jensen, M. C., & Meckling, W. H. (1976). Theory of the firm: Managerial behavior, agency costs and ownership structure. *Journal of Financial Economics*, 3(4), 305–360. <https://doi.org/https://dx.doi.org/10.2139/ssrn.94043>
- Kamolsakulchai, M. (2015a). The Impact of the Audit Committee Effectiveness and Audit Quality on Financial Reporting Quality of listed company in Stocks Exchange of Thailand. *Rev. Integr. Bus. Econ. Res*, 4(2), 328–341. [www.sibresearch.org](http://www.sibresearch.org)
- Kamolsakulchai, M. (2015b). The Impact of the Audit Committee Effectiveness and Audit Quality on Financial Reporting Quality of listed company in Stocks Exchange of Thailand. *Rev. Integr. Bus. Econ. Res*, 4(2), 328. [https://www.sibresearch.org/uploads/2/7/9/9/2799227/riber\\_sh14-269\\_328-341.pdf](https://www.sibresearch.org/uploads/2/7/9/9/2799227/riber_sh14-269_328-341.pdf)
- Mardani, Basri, Y. M., & Rasuli, M. (2020). Pengaruh Komite Audit, Audit Internal, dan Ukuran Perusahaan Terhadap Pengungkapan Kecurangan pada Perusahaan Perbankan yang Terdaftar di BEI 2018. *Jurnal Al-Iqtishad*, 1(16), 1–17. <https://doi.org/http://dx.doi.org/10.24014/jiq.v16i1.9927>
- Permatalia, R., & Haryono, S. (2021). Pengaruh Kualitas Komite Audit dan Kualitas audit Terhadap Kualitas Pelaporan Keuangan Perusahaan. *Jurnal Ekonomi Dan Perbankan Syariah*, 7(2), 126–134. <https://garuda.kemdikbud.go.id/documents/detail/2314378>
- Pratiwi, S. P., & Aufa, M. (2023). Pengaruh Sistem Pengendalian Internal Dan Teknologi Informasi Terhadap Kualitas Laporan Keuangan Perusahaan. *Jurnal Mirai Management*, 8(2), 321–330. <https://journal.stieamkop.ac.id/index.php/mirai/article/view/5306/3505>
- Rezra, E. P. (2022). Pengaruh Kualitas Auditor Terhadap Kualitas Laporan Keuangan pada Perusahaan Pembiayaan yang Terdaftar di Bursa Efek Indonesia (BEI) TAHUN 2016 – 2020. *Jurnal Ilmiah Akuntansi Dan Keuangan*, 4(3), 1575–1583. <https://journal.ikopin.ac.id/index.php/fairvalue/article/view/887>
- Sepasi, S., Deilami, Z. D., & Tavakoli, S. M. (2017). Internal Audit, Board of Directors and Financial Reporting Quality. *International Journal of Finance and Managerial Accounting*, 2(8), 63–75. [https://journals.srbiau.ac.ir/article\\_11802\\_f2540d2070374c41221bccd811a3a450.pdf](https://journals.srbiau.ac.ir/article_11802_f2540d2070374c41221bccd811a3a450.pdf)
- Sihite, R. N., & Holiawati. (2017). Pengaruh Standar Akuntansi Pemerintah, SPI dan Kompetensi Staf Akuntansi terhadap Kualitas Laporan Keuangan. *Jurnal Aset (Akuntansi Riset)*, 9(2), 81–92. <https://ejournal.upi.edu/index.php/aset/article/view/9231/5832>
- Sitorus, E. T., Setiyawati, H., & Mappanyuki, R. (2019). The Effectiveness of The Internal Control System on The Quality of Financial Statements With The Implementation of Internal audits as A Moderation Variable.

- International Conference on Rural Development and Entrepreneurship 2019: Enhancing Small Business and Rural Development Toward Industrial Revolution 4.0*, 1386–1400. [http://maks.pasca.mercubuana.ac.id/wp-content/uploads/2022/06/12.06\\_Sitorus-Setiawati\\_-Mappayunki.pdf](http://maks.pasca.mercubuana.ac.id/wp-content/uploads/2022/06/12.06_Sitorus-Setiawati_-Mappayunki.pdf)
- Stevani, I., & Meirini, D. (2023). Analisis Kualitas Laporan Keuangan Perusahaan yang Terdaftar di Bursa Efek Indonesia (BEI) Sebelum dan Selama Pandemi Covid-19. *Jurnal Akuntansi Dan Pajak*, 23(2), 1–13. <https://doi.org/http://dx.doi.org/10.29040/jap.v23i2.7460>
- Sunyoto, D. (2016). *Metode Penelitian Akuntansi* (D. Sunyoto, Ed.; Cet 1). Refika Aditama.
- Suryana, A., & Pitaloka, L. I. (2019). Pengaruh Kualitas Audit Terhadap Kualitas Pelaporan Keuangan pada Inspektorat Kota Sukabumi. *Jurnal Ekonomedia*, 8(01), 118–128. <https://journal.stiepasim.ac.id/index.php/ekonomedia/article/view/20/14>
- Zahroh, Y. F., & Hermanto, S. B. (2018). Pengaruh DER, Profitabilitas, Kualitas Auditor, Opini Audit dan Ukuran Perusahaan Terhadap Ketepatan Waktu. *Jurnal Ilmu Dan Riset Akuntansi*, 7(11), 1–17. <http://jurnalmahasiswa.stiesia.ac.id/index.php/jira/article/view/1336/1396>