



## DEVELOPING ORDER AND CUSTOM PRODUCTION INFORMATION SYSTEM WITH ORDER TRACKING SYSTEM IN BATIK BALQIS COLLECTION

SELVI CARLINA  
PRIMA AYUNDYAYASTI\*

Politeknik Negeri Semarang

\*prima@polines.ac.id

**Abstract:** Batik Balqis Collection is a boutique and batik producer that most of the goods are self-produced. In conducting their business, Batik Balqis Collection provides services in the form of custom orders that are still carried out manually, so it is difficult to describe the details of the order design and inaccuracies in calculating the cost of goods manufactured for each order. This research aims to design and develop order and custom production information systems with tracking information for Batik Balqis Collection customers. The method used to develop the system is the Prototype method. The prototype method phase consists of initial requirement, design, prototyping, customer evaluation, review and update, system development, and system implementation. Data collection methods used are interviews and observation. The system's outputs are purchase report, order report, material inventory report, work in process inventory report, finished good inventory report, and cost of goods manufactured report. By implementing this system, users are expected to run their business processes more efficiently.

**Keywords:** Design of Application, Order and Custom Production Information System, Tracking, Cost of Good Manufactured, Prototype.

### INTRODUCTION

Information system and technology have become very important components for the success of businesses and organizations. The development of information technology is progressing along with time. These developments can be seen in the use of information technology in a company's business activities. All of the business activities that happened in a company related with their business sectors are inseparable from the influence of information technology. The role of information technology in various aspects of business activities can be understood as a technology that focusses on regulating information systems with the use of computers and information technology to meet the information needs of the world of business very fast, timely, relevant, and accurate.

Behori and Holis DM said in their research that with information technology human can carry out activities easily, beside that the process of implementing task also can be carried out in a relatively short period of time. The increasingly sophisticated information media in the world of business keeps competition going up, such as in the trade and entrepreneurship sectors (Behori and Holis DM, 2017). A web-based information system to order customized jersey t-shirts in Malang was designed using ICONIX process as the development concept. ICONIX process is a method focusing on user's requirements and simplify the analysis, design, and implementation. Thus, the development of the system is more efficient (Wisono, Pramono and Saputra, 2019). A customized order of furnitures company in Bali applied a web-based ordering system to organize their business. The system could schedule custom furniture's measurement process, generate measurement document, sales order, quality control, invoice, process tracking, and so on (Utama, Putra and Satwika, 2019).

Batik Balqis Collection is a boutique and producer of batik founded in 2006 and is located at Jalan Kampung Batik Gedong 343, Semarang. The boutique's products have been sold to several islands in Indonesia and even abroad such as Argentina, Australia, Netherland, Japan, and so on because of the resellers who sold their products. The turnover from this industry reaches Rp 80.000.000,00 to Rp 100.000.000,00 per month and has gained net profit of more than Rp 25.000.000,00 per month.

Various obstacles are often experienced by Batik Balqis in carrying out their business process. Of the many business processes in Batik Balqis, the processing of sales transactions, especially orders, is the most complex according to the owner. Processing order transactions not only related to customers but also with batik makers and tailors related to cash disbursements and debts that will appear as a result of the transaction.

Batik Balqis serves ordering fabrics and custom clothes according to customer's desire. The duration of each order is different depending on the level of difficulty of making the order. Sometimes customers have difficulty in specifying what products that they want, such as when ordering fabric, they will be confused in specifying the batik pattern that they want. Similarly, when ordering custom clothes, they are sometimes confused in specifying the clothes design, collar design, sleeve design, and so on. As the result of these problems, the owner must find and recommend many fabric samples and clothing models to customers that take a long time. Therefore, making electronic catalogs is the alternative way to solve these problems.

In processing customer order, Batik Balqis has difficulty remembering orders especially orders for custom clothes, which of course each customer has a different design, so they have difficulty when they want to carry out searching for customer orders and must go to the tailor one by one. This is of course also considered to be less practical because it is a waste of time.

In carrying out their business, Batik Balqis always tried to satisfy their customers through the services provided. Batik Balqis wants their customers to receive information about their order status through order tracking. The purpose of providing this information through tracking orders is that customers do not have to ask several times about their order or even come to the boutique just to ask about the order process. Providing of information through tracking orders is felt right to improve Batik Balqis service to their customers, so an information system that is equipped with an order tracking system is needed as a solution to this problem.

One function in the production sector that is very important is calculating the cost of production. Inaccuracies in calculating the cost of production will have a negative impact, for example in determining the amount of the selling price of products offered to buyers whether it is right or not. Batik Balqis in their daily production process, determines the cost of goods of the order based on the standard cost which the tariff has been determined in advance to batik makers and tailors and other expenses during production until delivery to customers. Therefore, Job Order Costing Method is the right method for Batik Balqis to calculate the cost of production. This method is very suitable to be applied to companies that produce products based on order and fees are charged for each order which the cost has been agreed at the outset.

Based on the description above, an integrated information system is needed between the order and production. Making this information system will greatly help Batik Balqis in managing business processes and accelerating decision making for the progress of their business. With this background, the research proposed with the title "Developing Order and Custom Production Information System with Order Tracking System in Batik Balqis Collection".

The aims of this research are to design and develop an order and custom production information system with order tracking system at Batik Balqis Collection and present Cost of Goods

---

Manufactured Statement based on Job Order Costing Method at Batik Balqis Collection.

### **Information System**

Romney said that information system is ways that are organized to collect, store, manage, control, and report information in such a way that an organization can achieve their intended goals (Krismiaji, 2010). Information system is a network of procedures that are interconnected, gathered together to carry out activities or completion of a particular goal (Azzaky, 2016). According to Novianti and Setiawan (Novianti and Setiawan, 2017), information system that use computer is usually called Computer-Based Information Systems (CBIS). In practice, the term information system is more often used without computer-based frills even though in reality computer is an important part.

### **Job Order Costing**

Job Order Costing Method is a method of collecting the cost of products where production costs are collected for certain orders and the production cost per unit of product produced to fulfill the order is calculated by dividing the total production cost for the order by the number of product units in the order (Hermanto, 2016). According to Sujarweni, job order costing is the calculation of costs for producing products and determining the cost of goods of company's products based on consumer orders (Irwanto, Randa and Juliani, 2017).

In the English Oxford Living Dictionaries (*English Oxford Living Dictionaries*, 2019), custom as a noun is regular dealings with a shop or business by customers. While custom as an adjective is made or done to order. Cambridge Dictionary (*Cambridge Dictionary*, 2019) stated that custom is the support given to a business, especially a shop, by the people who buy things or services from it.

### **Order Tracking System**

Tracking literally means following the path, or in another meaning is an activity to follow in the footsteps of an object (Juansyah, 2015). McLeod said that tracking is an activity of displaying information on the sender's goods through a certain media (Sitanggang, Magdalena and Martha, 2014). Shamsuzzoha and Petri said that organizational managers noticed this tracking system as a means of strengthening their market position through improved customers satisfaction and implementation of information technology (Shamsuzzoha and Helo, 2011).

## **RESEARCH METHOD**

### **Scope of The Research**

This research was conducted at Batik Balqis Collection, this business is engaged in the production and sales of various types of batik typical Semarang. Batik Balqis products diverse range from batik fabrics to clothing and accessories such as bags and wallets. This business was founded by Mr. Ibrahim in 2006 which was initially appointed directly by the local Village Hall to sell batik in Kampung Batik Semarang. Until now, Batik Balqis products have been distributed to various regions in Indonesia and even abroad such as Argentina, Australia, Netherland, Japan, etc because of resellers who sold their product.

### **Type of Data Required**

Data sources needed are primary data and secondary data. The primary data used in this research is data taken directly through interviews with the owners of Batik Balqis and making observations of business processes in detail that are currently used. Secondary data used is information taken from books, journals, scientific articles, or the internet.

### **Data Collecting Method**

In this research, the method used to collect data are interview and observation. Observation is done by visiting Batik Balqis Collection and observing the business process. While the interview method in this research is done by asking question to the owner and staff about the order, production process,

and other explanations related to this research.

### **System Development Method**

The system development method used in this research is prototype method. The stages of system development using the prototype method are as follows:

1. Initial Requirement  
The initial stage of the prototype method is to collect system requirements that can be known from the results of observations and interviews with Batik Balqis Collection. This stage will present information about the requirements needed to create a new system in detail by going through several stages of analysis covering analysis of ongoing system weaknesses, system requirements analysis, and ending with feasibility analysis of the proposed system.
2. Design  
The second stage is designing the system to describe the system to be developed. System design in this research uses Unified Modeling Language (UML). There are several types of diagram UML, as follows:
  - a. Use Case Diagram
  - b. Class Diagram
  - c. Sequence Diagram
  - d. Deployment Diagram
3. Prototyping  
The next step is to build a prototype method based on the requirements that have been collected and the design that has been designed using UML diagrams. Construction of the intended prototype is by designing interfaces and designing databases. The interface is part of the computer and software that can be seen, heard, touched, and talked to, either directly or with certain processes of understanding. Information technology has an interface that functions to bridge between users and the technology. Database design is based on information or requirements obtained when identifying requirements by interviewing and analyzing requirements and the feasibility of the system.
4. Customer Evaluation  
At this stage the user evaluates the prototype or system design proposed by the programmer. If the proposed prototype is less or not in line with user expectations, then the process will proceed to the review and update stages but if the prototype is in line with the user's expectations, the process will continue to the development stage.
5. Review and Update  
This stage is carried out when there is a user evaluation of the proposed prototype. At this stage repairs and updates are made to the system design (prototype) until the design is truly in accordance with user needs. Update is done by re-designing and re-prototyping to meet all user needs.
6. Development  
This stage is the stage of implementing the program code based on the results of the previous stages. The development software used in building the system is Microsoft Visual Studio Professional 2013 for Order and Custom Production Information Systems while for the Tracking Order System using Notepad++ and will be translated into PHP programming languages. MySQL is used as its database, and for bridging between software developers and MySQL using XAMPP.
7. Testing  
Testing is carried out on the input to the system output. Testing is carried out with the aim that the application has been built in accordance with the design and the system can run well and there is

noerror. This research uses Black Box and Grey Box Testing for system testing.

#### 8. Implementation and Maintenance

This stage is done by the user after the system is finished and given to them. Users can implement the system and maintain the system regularly. So, the stages of the prototype carried out in this study stopped at the testing stage because the implementation and maintenance stages were carried out by the user.

## RESULTS AND DISCUSSION

### Initial Requirement

The system that has been running in Batik Balqis Collection related to the sales system on orders and production can be broken down into two business processes which include business process for processing order transactions and business process for production. Order transactions start from customer who came to the boutique to order products according to their customized design. If the customer wanted to order fabric, the employees will offer some fabric patterns and the design of custom clothes as well. After the customer chooses the motif or model they want, then the boutique and the customer will agree on the deadline for completing the order. For fabric orders, after customers choose the motif they want, Batik Balqis employees will check the inventory. If the inventory is less than the amount ordered by the customer, then the deficiency will be recorded for order transaction. If it is sufficient, it will go directly to the payment process. After agreeing to the deadline, the cashier will calculate the order. Customers can pay with full payment or down payment (DP). If the customer gives a DP, the lack of payment will go to the receivable list and will be billed if the order is complete. Then the owner will make an invoice and give it to the customer. A copy of the invoice will be used as the basis for recording in the book. If the customer wants to pay off the order, the payment will be received and the receipt is given to the customer.

Production is carried out if an order is entered and is not in stock. Employee check the inventory of raw materials and auxiliary materials. If the raw material and auxiliary materials needed are not available, the owner will first buy to the suppliers and then hand them over to the subcontractors. After subcontractors receives the required materials, they will immediately process it into finished goods and then the finished product is sent back to the boutique. Next, the Production Staff will contact the customer to let them know that their product is finished.

The system weakness analysis is done using Root Cause Analysis (RCA) as an effective way to identify and solve problems in Batik Balqis Collections. RCA is one of the tools used in problem solving initiatives, to help find the root causes of problems that are being experienced. The analysis is conducted as follows:

1. Define the Problem
  - a. Customers have difficulty presenting the order that they want.
  - b. Difficulty remembering the design of each customer's order.
  - c. Difficulty tracking down orders produced in subcontracts.
  - d. There is no order statement.
  - e. The Cost of Goods Manufactured calculation for each product is incorrect.
  - f. Miscommunication between the customer and the owner.
2. Identification of Possible Causes
  - a. No product catalogs.
  - b. Recording of orders is not accompanied by design pictures.
  - c. There is no record of which subcontract produce the order.
  - d. Records of order transactions in books are not summarized into reports.

- e. Incorrect in determining the costs involved in making a product.
- f. There is no complete information about processing customer orders.
- 3. Identification of Root Causes
  - a. Orders are not recorded in full and data storage is still not regular.
  - b. Not using the right method for Cost of Goods Manufactured calculations.
  - c. No information about order tracking intended for customer.
- 4. Submit Implementation and Solutions

Based on the root cause of the problem, the solution can be implemented by developing order and custom production information system with order tracking system in Batik Balqis Collection.

System requirement analysis includes hardware and software requirements, information needs, and user needs. The hardware to develop new system required a computer with minimum specifications of Intel Dual Core processor, 2GB RAM, 500GB hardisk, modem or Wifi connection, also standard monitor, keyboard, and mouse to perform the new system smoothly. The required software consisted of Microsoft Windows 7 operating system as the slightest, web browser, and Crystal Report. The information needed for the new system includes master data of Material Data, Product Data, Employee Data, Supplier Data, Subcontract Data, and Cost of Good Manufactured Details. As well as transaction data of Purchase Data, Order Data, Production Data, and Cash Disbursement for Production.

Feasibility analysis is conducted to assess whether the system to be built later can be operated properly or not, this analysis is carried out using the PIECES framework. The PIECES framework includes performance to determine whether the system can provide sufficient throughput and response time, information to find out whether the system can provide quality information for users, economy to find out whether the system can offer adequate levels and service capacity to reduce costs and increase profits, control to find out whether the system can offer better control for detecting system errors or fraud, efficiency to determine whether maximum use of available resources includes people and can minimize process delays, and service to find out whether the system can provide reliable services as needed the user.

**Table 1 Operational Feasibility According to PIECES**

Component	Old System	New System
Performance	Requires a relatively long time to produce an information because there is no adequate reporting system.	The time needed to produce information is relatively short, just click on the report menu.
Information	<ul style="list-style-type: none"> <li>a. Information generated regarding orders and productions is incomplete because the available data is inadequate.</li> <li>b. The information presented is sometimes late and not accurate because of human error.</li> </ul>	<ul style="list-style-type: none"> <li>a. The information produced is more complete in accordance with user needs.</li> <li>b. The information generated can be timely and more accurate.</li> </ul>
Economy	The cost of office stationery because recording transaction data is still done manually in the book.	There is no fee for office stationery because recording transaction data is computerized.
Control	There is no adequate control system.	System control is done by limiting user access rights. The implementation of a computerized system can create a control system for business activities carried out.
Efficiency	The risk of the length of time needed to find orders with subcontractors.	Save more time in searching orders for subcontractors.
Service	<ul style="list-style-type: none"> <li>a. Design selection for orders takes a long time.</li> <li>b. The recording and processing of transaction data takes a relatively long time because it is still done manually using books.</li> </ul>	<ul style="list-style-type: none"> <li>a. The time needed to choose a design can be shortened by the catalogs feature provided by the system.</li> <li>b. Data processing is easier, faster, and relatively accurate and offers a consistent format.</li> </ul>

Source: Processed primary data

Economic feasibility analysis is the most dominant thing from other feasibility aspects because the motivation for system development is inseparable from profit motives, so the profit and loss from system development must be calculated. An economic feasibility needs to be done to analyze the costs incurred and the benefits to be gained from developing a new system. System development can be said to be economically feasible if the number of benefits received is greater than the costs sacrificed. Economic feasibility can be measured by investment valuation methods which include Cost-Benefit Analysis (CBA), Return on Investment (ROI), Net Present Value (NPV), and Payback Period (PP).

**Table 2 Costs, Benefits and Proceed**

Description	Year 0	Year 1	Year 2	Year 3
<b>COST</b>				
Project Procurement Cost	Rp10.900.000	Rp238.800	Rp238.800	Rp238.800
Operational & Maintenance Cost	Rp0	Rp1.907.600	Rp2.063.760	Rp2.245.536
<b>TOTAL OF COSTS</b>	<b>Rp10.900.000</b>	<b>Rp2.146.400</b>	<b>Rp2.302.560</b>	<b>Rp2.484.336</b>
<b>BENEFITS</b>				
Tangible Benefits	Rp0	Rp700.000	Rp770.000	Rp847.000
Intangible Benefits	Rp0	Rp6.800.000	Rp7.480.000	Rp8.228.000
<b>TOTAL OF BENEFITS</b>	<b>Rp0</b>	<b>Rp7.500.000</b>	<b>Rp8.250.000</b>	<b>Rp9.075.000</b>
<b>Difference in Total Costs and Benefits</b>	<b>Rp10.900.000</b>	<b>Rp5.353.600</b>	<b>Rp5.947.440</b>	<b>Rp6.590.664</b>
<b>Depreciation</b>	<b>Rp0</b>	<b>Rp846.000</b>	<b>Rp846.000</b>	<b>Rp846.000</b>
<b>Proceed</b>	<b>Rp10.900.000</b>	<b>Rp6.199.600</b>	<b>Rp6.793.440</b>	<b>Rp7.436.664</b>

Source: Processed primary data

Calculations to measure how fast the investment will return are:

1) Payback Period

Investment	Rp 10.900.000
Proceed Year I	Rp 6.199.600
Proceed Year II	Rp 6.793.440
Proceed Year III	Rp 7.436.664

Investment Value	Rp 10.900.000
Proceed Year I	Rp 6.199.600 -
	Rp 4.700.400

$$\begin{aligned}
 \text{2nd Year Proceed} &= \text{Rp } 4.700.400 \times \frac{12 \text{ months}}{\text{Rp } 6.793.440} \\
 &= 8 \text{ months } 9 \text{ days}
 \end{aligned}$$

From the calculation above, the payback period shows 1 year 8 months 9 days.

2) Return on Investment

**Table 3 Cost and Benefit**

Year	Cost	Benefits
0	Rp 10.900.000	Rp -
1	Rp 2.146.400	Rp 7.500.000
2	Rp 2.302.560	Rp 8.250.000
3	Rp 2.484.336	Rp 9.075.000
<b>Total</b>	<b>Rp 17.833.296</b>	<b>Rp 24.825.000</b>

Source: Processed primary data

$$ROI = \frac{\text{Total Benefit} - \text{Total Cost}}{\text{Total Cost}} \times 100\%$$

$$ROI = \frac{Rp\ 24.825.000 - Rp\ 17.833.296}{Rp\ 17.833.296} \times 100\%$$

$$ROI = 39,2\%$$

A project with ROI of more than 0% is an acceptable project. The ROI in this project is 39,2%, meaning that the project is acceptable because it will give benefits of 39,2% of the investment cost.

### 3) Net Present Value

$$NPV = - \text{Investment} + \frac{\text{Proceed I}}{(1+i)^2} + \frac{\text{Proceed II}}{(1+i)^2} + \frac{\text{Proceed III}}{(1+i)^2}$$

$$= - Rp\ 10.900.000 + \frac{Rp\ 6.199.600}{(1+0,06)^2} + \frac{Rp\ 6.793.440}{(1+0,06)^2} + \frac{Rp\ 7.436.664}{(1+0,06)^2}$$

$$= - Rp\ 10.900.000 + Rp\ 5.517.621,93 + Rp\ 6.046.137,415 + Rp\ 6.618.604,486$$

$$= Rp\ 7.282.363,831$$

Based on the calculation above, the NPV is Rp 7.282.363,831.

## Design

In the design stage, it contains an explanation of the business process system to be built and the system model is designed using UML diagrams.

### 1. Use Case Diagram

The use case diagram of the proposed system shows the user's needs and the activities that will be carried out on the new system. The design was then submitted to the owner for later discussion and correction whether it was in accordance to their needs.

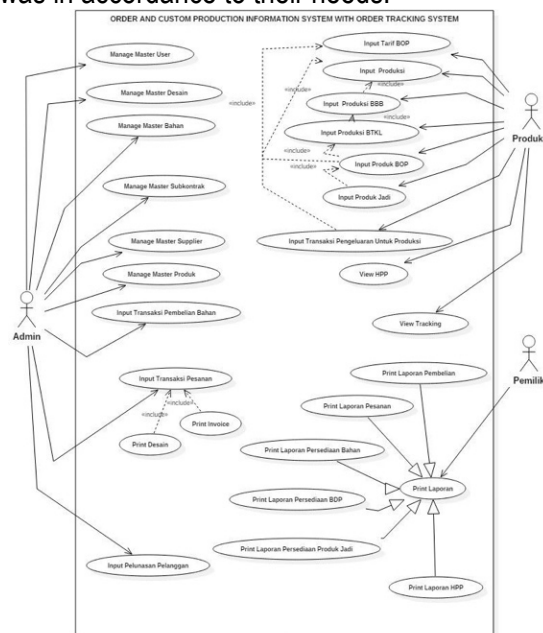

Source: Processed primary data  
**Figure 1 Use Case Diagram**



2. Class Diagram

Class diagram is used to display classes and packages on a system that will be used to build the system. In general, the system consists of 6 main masters namely design, material, product, supplier, subcontract, purchase, order, and production.

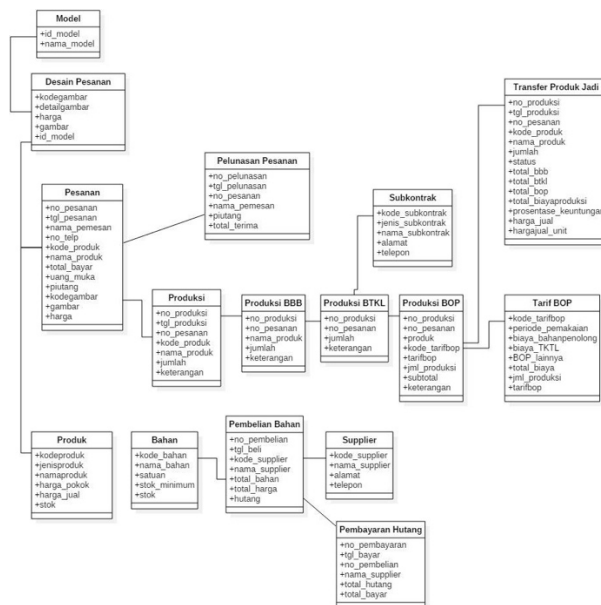

Source: Processed primary data  
**Figure 2 Class Diagram**

3. Sequence Diagram

Sequence diagrams are used to show the flow of information or messages sent from one object to another object. Following is the sequence diagram of the system built on the Balqis Batik Collection.

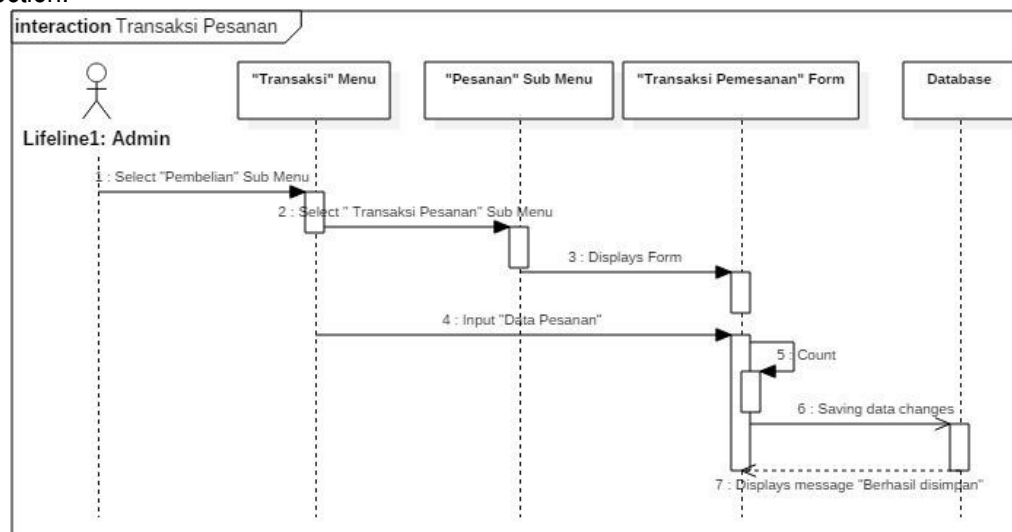

Source: Processed primary data  
**Figure 3 Sequence Diagram for Input " Transaksi Pesanan"**

4. Deployment Diagram

Deployment diagram is used to illustrate the details of how components are deployed in the system

infrastructure, where the components will be located (on what machines, servers or hardware), how the network capabilities at that location, server specifications, and other things that are physical. In this research, the system to be built is desktop-based for Order and Custom Production Information Systems while for Tracking Order System is web-based.

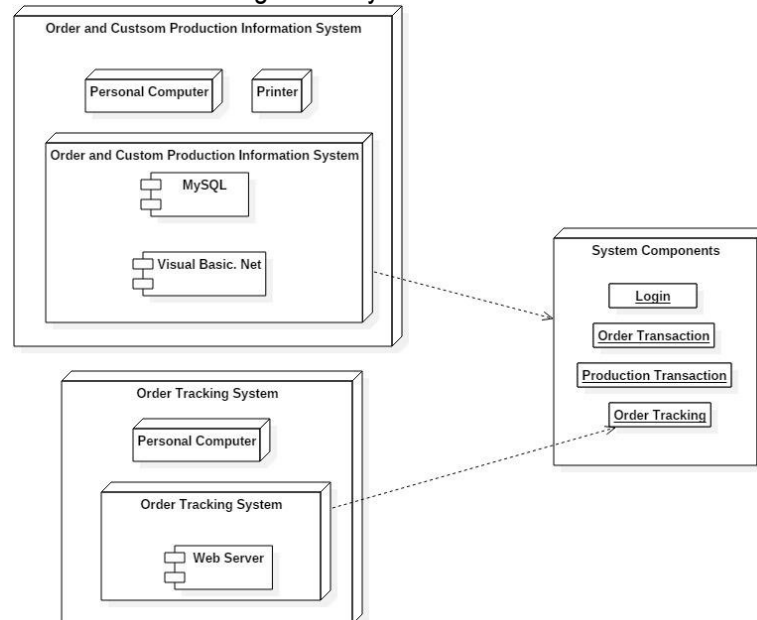

Source: Processed primary data

**Figure 4 Deployment Diagram**

User interface design describes the design of user interface page in the information system developed including the display of input and output forms. The interface design of the “Transaksi Pesanan” form to record order transactions is shown in the following figure.

Source: Processed primary data

**Figure 5 Design of “*Transaksi Pesanan*” Form**

### Prototyping

In the prototyping stage, a temporary system design is carried out before it is made into the actual application. The design will be evaluated by the customer to fulfill the customer's wants and needs. Prototype includes database design and user interface design.

**Table 3 Database Design for Table of “Pesanan”**

Field Name	Data Type	Description
<i>no_pesanan</i>	varchar (15)	Using varchar for data type because the record on field is alphabet and number
<i>tgl_pesanan</i>	Date	Using date for data type because the record on field is date.
<i>tgl_jadi</i>	date	Using date for data type because the record on field is date.
<i>namapemesan</i>	varchar (80)	Using varchar for data type because the record on field is alphabet and number.
<i>totalbayar</i>	decimal (13,0)	Using decimal for data type because the record on field is number.
<i>Dp</i>	decimal (13,0)	Using decimal for data type because the record on field is number.
<i>Sisa</i>	decimal (13,0)	Using decimal for data type because the record on field is number.

Source: Processed primary data

User interface is the display of system interface that is built. The user interface for “*Input Desain Pesanan*” form is shown in Figure 6. Order Tracking System is provided to ease the customers to monitor their order status. To find out the status of the order, customers only enter the order number listed on the invoice, then information about the order status will appear. The interface for Order Tracking System is shown in Figure 7.

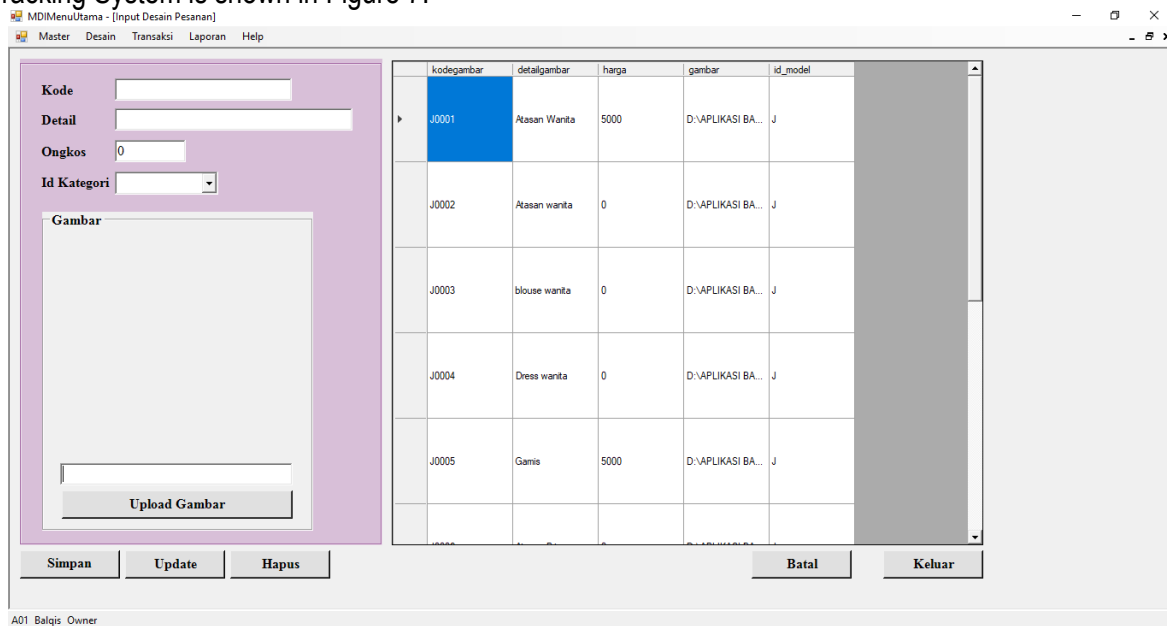

Source: Processed primary data

**Figure 6 Interface of “*Input Desain Pesanan*” Form**

**Cari**

No	No Pesanan	Nama Pemesan	Kode Produk	Nama Produk	Tanggal	Status
1	PS-190830064312	Ayu	BLTF01	BAJU BLOUSE TANPA FURING	2019-08-30 00:00:00	Pesanan diterima
2	PS-190830064312	Ayu	BLTF01	BAJU BLOUSE TANPA FURING	2018-10-17 00:00:00	Pesanan masuk produksi
3	PS-190830064312	Ayu	BLTF01	BAJU BLOUSE TANPA FURING	2019-08-30 00:00:00	Pesanan dalam pemilihan bahan untuk produksi
4	PS-190830064312	Ayu	BLTF01	BAJU BLOUSE TANPA FURING	2019-08-30 00:00:00	Pesanan sedang dalam pengerjaan
5	PS-190830064312	Ayu	BLTF01	BAJU BLOUSE TANPA FURING	2019-08-30 00:00:00	Pesanan sudah jadi

Source: Processed primary data  
**Figure 7 Order Tracking System**

### Customer Evaluation

At the customer evaluation stage, the customer evaluates the proposed system design from the previous stage. Based on the evaluation results of the proposed design there are some additional features in the *Data Pemesanan* display. The *Data Pemesanan* display is considered unrealistic, because the orders that have been produced are still showing and the date filter is not provided in there.

### Review and Update

In the review and update stage the developer makes improvements and updates to the designs and prototypes that have been evaluated to meet the needs and expectations of users. Based on the results at the customer evaluation stage, there are some additional improvements to the proposed prototype. Therefore, a review and update need to be done to improve the prototype that was built. The results of the prototype improvement are illustrated with user interface on Figure 8.

### Development

This stage is the actual system development stage by writing programming instructions into a complete information system. After conducting several evaluations and testing by developers and users, the results obtained in accordance with user's needs and desires.

The screenshot shows a web-based form titled "Form Data Pemesanan". At the top, there is a search bar labeled "Cari" and a date range selector "Tanggal" with values "2019-08-21" and "s/d 2019-08-21". Below this is a table with the following columns: No Pesanan, Nama Pemesan, Telepon, Tanggal Pesan, Tanggal Jadi, DP, and Total. The table contains two rows of data:

No Pesanan	Nama Pemesan	Telepon	Tanggal Pesan	Tanggal Jadi	DP	Total
PS-190821033937	selvi	08765353534	21/08/2019	21/08/2019	0	0
PS-190821033941	sarah	089726372663	21/08/2019	21/08/2019	500000	800000

At the bottom of the form, there are buttons for "Tambah", "Ubah", "Cetak Katalog", and "Hapus".

Source: Processed primary data  
**Figure 8 "Data Pemesanan" Form**

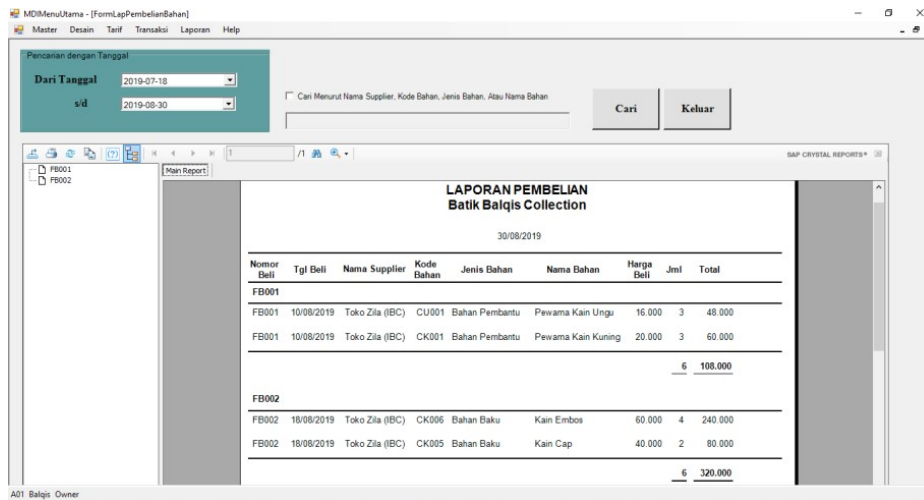

Source: Processed primary data  
**Figure 9 Report for “Pembelian”**

**Testing**

The testing stage is carried out to test whether the system that was built is running in accordance with what is expected. System testing is done by Black Box Testing and Grey Box Testing. Black Box testing is done to observe the results of execution through test data and check the functionality of the software. Black box testing on this system was conducted on several existing points. Grey box testing is a software testing technique where the functionality of software testing is tested without looking at the internal code structure, implementation details and knowledge of the internal path of the software. The testing was entirely based on software requirements and specifications.

**Table 4 Black Box Testing**

Items	Testing Details
Login	Login with several different users according to their respective access rights
Master Data User	Add, update, delete, data user
Master Data Bahan	Add, update, delete, and view data user
Master Data Supplier	Add, update, delete, and view data supplier
Master Data Subkontrak	Add, update, delete, and view data subkontrak
Master Data Produk	Add, update, delete, and view data produk
Master Tarif BOP	Add, update, delete, and view data tarif BOP
Transaksi Pembelian	Add purchase transaction
Hapus Pembelian	Delete purchase transaction
Transaksi Pelunasan Hutang	Add and view debt repayment transaction based on loans from purchase transactions that have not been paid off
Input Desain Pesanan	Add and view pictures of customer order
Transaksi Pesanan	Add order transaction
Hapus Pesanan	Delete order transaction
Transaksi Penerimaan Pelunasan	Add and view receivables repayment receipt transactions from customers
Input Produksi	Add and view production data
Input Produksi-Biaya Bahan Baku	Add raw materials for production, update and view production data
Input Produksi-Biaya Tenaga Kerja Langsung	Add direct labor cost for production, update and view production data

Source: Processed primary data

## CONCLUSIONS

Based on research conducted on Batik Balqis Collection, several problems can be found that affect the smoothness of business processes, namely difficulty in determining the details of order design, misunderstanding between the owner and the subcontract about the costs paid and where the order is produced, inaccuracy in determining the cost of goods manufactured for each product, and there is no information about tracking order for customers.

The above problems can be overcome by designing and developing an order and custom production information system with an order tracking system, where the application consists of 2 (two) bases namely desktop-based for managing information about orders and production, while web-based to provide tracking information about orders for customer.

The calculation of cost of goods manufactured in the application is also in accordance with the Job Order Costing method, where costs are calculated based on the product ordered. The system that has been developed is expected to provide value for the smooth running of business processes in the Batik Balqis Collection.

Recommendations that can be given to further research for the development of this system are to develop this application into a web-based system so that customers can place an order online without having to come to the boutique first and adds an income statement so that the system user knows the profit or loss that the company produces while operating within a certain time period.

## REFERENCES

- Azzaky, G. H. (2016) 'Perencanaan Sistem Informasi Berbasis Web Untuk Sistem Persediaan Dan Sistem Pemesanan Produk Jadi Konveksi Seragam Pada Pd.Devi Khusus', *e-Proceeding of Engineering*.
- Behori, A. and Holis DM, N. (2017) 'Sistem Informasi Order pada Koperasi Jahit Assyarif Menggunakan PHP dan MySQL', *AiTech*, 3(2), pp. 113–119. Available at: <http://ejournal.amiki.ac.id/index.php/Aitech/article/view/52>.
- Cambridge Dictionary* (2019). Available at: <https://dictionary.cambridge.org/dictionary/english/custom> (Accessed: 13 May 2019).
- English Oxford Living Dictionaries* (2019). Available at: <https://en.oxforddictionaries.com/definition/custom> (Accessed: 13 May 2019).
- Hermanto, B. (2016) 'Perhitungan Harga Pokok Pesanan (Job Order Pada Pt. Rachmat Perdana Adhimetal Costing) Produk ??Brkt Number Plate K56? Pada Pt. Rachmat Perdana Adhimetal', *WIGA: Jurnal Penelitian Ilmu Ekonomi*, 6(1), pp. 53–62. doi: 10.30741/wiga.v6i1.99.
- Irwanto, Randa, P. and Juliani (2017) 'Analisis job order costing pada cv media mandiri', *Jurnal Bisnis Administrasi*, 06(02), pp. 37–46.
- Juansyah, A. (2015) 'Pembangunan Aplikasi Child Tracker Berbasis Assisted – Global Positioning System ( A-GPS ) Dengan Platform Android', *Jurnal Ilmiah Komputer dan Informatika (KOMPUTA)*, 1(1), pp. 1–8. Available at: [elib.unikom.ac.id/download.php?id=300375](http://elib.unikom.ac.id/download.php?id=300375).
- Krismiaji (2010) *Sistem Informasi Akuntansi*. Yogyakarta: UPP STIM YKPN.
- Novianti, N. and Setiawan, R. (2017) 'Pengembangan Sistem Informasi Jasa Menjahit Berbasis Web Pada Ganesha Tailor Garut', *Jurnal Algoritma*, 13(2), pp. 246–253. doi: 10.33364/algoritma/v.13-2.246.
- Shamsuzzoha, A. and Helo, P. (2011) 'Real-time tracking and tracing system: Potentials for the logistics network', ... of the 2011 International Conference on ..., pp. 242–250.
- Sitanggang, D. Y., Magdalena, L. and Martha, D. (2014) 'APLIKASI SISTEM PENGECEKAN TARIF

DAN TRACKING STATUS PENGIRIMAN BARANG MENGGUNAKAN PONSEL BERBASIS JAVA ( Studi Kasus : PT . JNE CIREBON )', 4(2), pp. 122–135.

Utama, D. W., Putra, I. G. L. A. R. and Satwika, I. P. (2019) 'Rancang Bangun Sistem Informasi Pemesanan Custom Furniture Berbasis Website', *J-SAKTI (Jurnal Sains Komputer dan Informatika)*, 3(1), p. 53. doi: 10.30645/j-sakti.v3i1.96.

Wisono, J. O., Pramono, D. and Saputra, M. C. (2019) 'Analisis dan Perancangan Sistem Informasi Pemesanan Customized Jersey pada Injers Malang Berbasis Web', 3(4), pp. 3677–3686.