

Smart Lighting System Using LoRa WAN Technology

Ashish Jha, Menuka Maharjan

Assistant Professor, Department of Computer Science and Engineering
Nepal Engineering College, Changunarayan, Bhaktapur

Received: 14 April 2021; Accepted: 28 July 2021; Published: 08 February 2022

Abstract: The augmentation of the populace and the addition of the street have expanded the no of the streetlamp, for the street and individual's security, which builds the venture and energy. Lighting burns-through satisfactory measure of energy in both open-air and indoor. Anyway, various methodologies are being proposed for making the framework energy effective and updated with the most recent innovation. This exploration gives the exact and the best command over the energy proficient road lighting framework. It will give the functional execution utilizing LoRa and the Arduino just as the data utilizing different sensors. This exploration provides conservation of energy and with efficient monitoring of light as well as accident that happen in road due to less efficacy presences of light.

Index Terms: Street Lighting System, LoRa, Arduino, Sensors.

1. Introduction

Voyaging is essential for our day by day lives, everyone must be in street, may it be going to work, going to class, or going to the supermarket to purchase any material. Each time we travel, we invest significant time and energy in street without light which is preposterous, to go in the day time we need daylight and in the night either moonlight or some other lighting machines however in street for vehicles to go in night require light without it is exceptionally perilous and unsafe. In this way, streetlamp is introduced in street to assist vehicles with welling walker in the street. Brilliant lighting adds knowledge and control to streetlamps to help diminish the biggest energy cost of a normal City. Brilliant lighting gives far off lighting control that can all the more likely change the measure of time the light is gone on to limit energy costs without relinquishing public security. Canny streetlamp alludes to public road lighting that adjusts to development by people on foot, cyclists, and vehicles. Shrewd road lighting likewise alluded to as versatile road lighting, diminishes when no movement is recognized. Streetlamps can be made astute by putting cameras and sensors on them, which empowers them to identify development. Extra innovation empowers the streetlamps to speak with each other. Various organizations have various perspectives in creating brilliant streetlamps. For quite a while, prior LED is viewed as the future enlightenment. Indeed, expanding public interest for proficiency and advances in innovation have made LEDs probably the best answer for indoor lighting, concerning productivity and life expectancy. For public brightening, anyway, other light sources as a focused energy release lights and anodes fluorescent, are as yet serious as far as strength, proficiency, and cost. The vital thought of this entire exploration is to build up the mechanized and controlled streetlamp as per prerequisite the street and vehicles and the voyager. The main objective is to design and implement an automated lighting system embedded with a different sensor that is capable of precisely controlling and monitoring the street light & Making the system energy efficient and absolutely low maintenance cost and reduced manual work.

2. Literature Review

By and large, extraordinary work has been proposed on streetlamp utilizing both wires just as remote innovation. In wired innovation power line correspondence (PLC) is the best and achievable for the effectiveness just as client fulfillment with issue observing and location [1]. Using shrewd wire/remote for programmed streetlamp the board framework has been troublesome. The remote sensor directs every streetlamp should be furnished with various kinds of microcontroller to quantify its working condition (for example lighting power, current/voltage, temperature, and so forth) was gathered and moved by the methods for radio recurrence. The correspondence was done in two sections, one is short reach correspondence for information trade between streetlamps the and second is long-reaching each to trade information from streetlamp and the information center [6].

2.1 Street Light

Giving Street Light is perhaps the most significant and costly duties of a city lighting can represent 10-38% of the absolute energy bill in a regular urban area around the world. Road lighting is an especially basic worry for public experts in agricultural nations as a result of its essential significance for monetary and social solidness. Wasteful lighting squanders critical monetary assets every year, and helpless lighting makes hazardous conditions. Energy productive advances and configuration can cut the road significantly. These investment funds can wipe out or diminish the requirement for new producing plants and give the cash-flow to elective energy answers for populaces in far-off territories. These cost reserve funds can likewise empower regions to extend road lighting to extra regions, expanding admittance to lighting in low-pay and other underserved territories. Also, enhancements in lighting quality and extension in administrations can improve security conditions for both vehicle traffic and walkers. An all-around planned, energy-productive road lighting framework should allow clients to go around evening time with great permeability, in wellbeing and solace, while lessening energy use and costs and improving the presence of the area. Then again, inadequately planned lighting frameworks can prompt helpless permeability or light contamination, or both. Regularly, road lighting is ineffectively planned and deficiently kept up (e.g., there are enormous quantities of wore out lights), and uses outdated lighting innovation—in this way burning-through a lot of energy and monetary assets, while frequently neglecting to give top-notch lighting. The Bureau of Energy Efficiency, because of Nepal Electricity Authority measurements, has assessed net energy utilization for public lighting to be 4.98 billion kWh in Nepal for the years 2014-2015[World Data].

2.2 Energy-efficient Street Lighting

Energy Efficient road lighting projects have a few phases as appeared in figure 1.

In the most recent couple of years, innovation head shave prompted the improvement of energy-effective lighting frameworks that comprise at least one part like low misfortune weights, steady wattage extreme focus electronic counterbalances, energy-productive Illumina, tors, and Better checking and control systems.

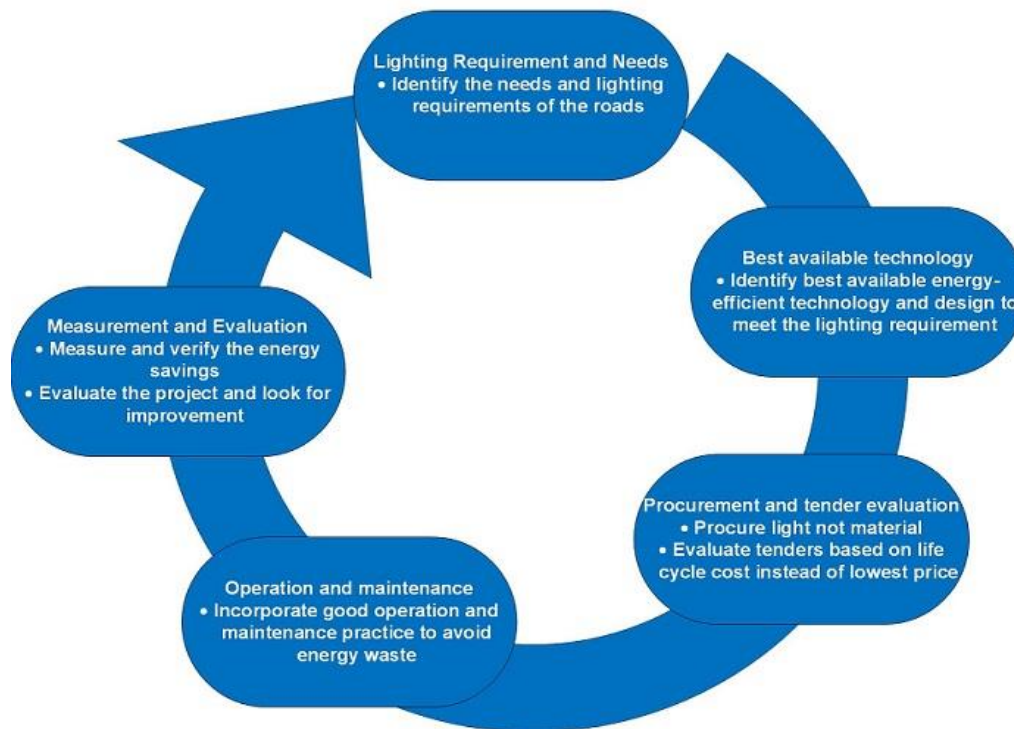

Fig.1. Street Lighting Project Cycle

2.3 Requirements for Streets Lighting

Planning or altering a current plan in road lighting has some key prerequisites, it is critical to initially comprehend the light necessities of the streets. In Indian norm, lighting is as indicated by the traffic thickness of the street and as needs are, founded on grouping in the establishment code, concerned designer coordinates the classification the of the street at that point plans and gives establishment determinations to the specific road lighting framework.

2.4 Choice between retrofitting and new installation

Because of the lighting prerequisites and motivation behind establishment, thinking about the age of the current framework, expansive choices must be taken on whether a new plan and establishment are required or simply retrofitting the current framework achieves the work. To have a retrofit done, it very well may be in two structures, either totally uncover from the ground including links or utilizing the current posts and afterward change the cabling and different frill.

a) Retrofitting

Retrofitting is considered for energy and upkeep reserve funds. Retrofitting or substitution is now and then essential in situations where light isn't appropriated effectively, or where a shaft has been harmed. There are extraordinary open doors for huge upgrades in productivity since post areas try not to change.

b) Complete or new installation

This alternative involves totally eliminating the current framework and supplants it with new gear. While another form of this establishment is to plan and introduce a totally new framework where road lighting had not recently existed. This furnishes extraordinary adaptability in the plan concerning amount what's more, post areas. At the point when a central avenue improvement project is arranged, totally new shafts and lighting apparatuses might be the most ideal alternative for the best energy-effective plan of the road lighting framework.

2.5 Surveying the technicalities of Street Lighting

Components utilized for lighting can be gathered by their on their capacities, which can commonly portray as electrical, primary and optical. These parts include:

a) Structural/ Civil

- Steel or any metallic Poles
- Concrete pole Bases (Foundation)

b) Optical Components

- Complete luminaries

c) Electrical

- Electric Lamps
- Current Ballasts
- Fuse Box for Service

Productive frameworks are intended to limit life cycle costs while accomplishing lighting necessities (e.g., least illuminance prerequisites to guarantee appropriate working and wellbeing of clients). To accomplish a powerful energy-proficient plan, it is basic to a mix of the appropriate light/counterweight that produces high lumens per watt along with installations that meet plan prerequisites which limits glare, light trespass, and light contamination.

2.6 Proper Usage & Routine Maintenance

High energy utilization in streetlamps can be decreased by instilling great upkeep schedules thusly:

- Defective lights should be supplanted alongside adornments also, wires
- Faulty links should be redressed early.
- Cable establishment should be done appropriately.
- Fuse box requires ordinary checking to dodge free contacts
- Keeping luminaire cover liberated from residue or earth builds light yield

A generous measure of energy investment funds can likewise be accomplished by introducing mechanical/electronic clocks or potentially sunlight sensors for turning streetlamps on and off.

2.7 Metering & Monitoring

Metering is a significant angle in the road lighting framework, it serves to accurately screen the energy utilization and execution of the framework, it likewise quantifies and confirms the investment funds in the event that the framework should be refreshed. Damaged meters should be supplanted quickly to dodge normal charging by power sheets. Trendsetting innovations like distant observing of exchanging focuses in streetlamps can be used to record data, for example,

- Instant energy utilization
- Trend examination
- Patterns of energy utilization

These would then be able to be utilized to recognize and investigate explanations behind increments or diminishes in energy utilization.

2.8 Measurement & Verification

Estimation and confirmation is utilized to give a dependable, straightforward, and replicable cycle which can be utilized to evaluate and survey the effects and maintainability of actualized energy-effectiveness projects. The fundamental rule in M&V is contrasting the deliberate power utilization furthermore, request when execution to decide the power investment funds.

2.9 LoRa technology

LoRa implies Long Range. This innovation empowers availability, ongoing examination, revealing, and extra capacities, for example, geolocation. Infiltrates in thick metropolitan and profound indoor conditions, Connecting to sensors 15-30 miles away in provincial regions, empowers multi-year battery lifetime of as long as 20 years or more, underpins a huge number of message per base station, empowers following an application without GPS or extra force utilization, LoRaWAN detail guarantees interoperability among applications, IoT arrangements suppliers and telecom administrators, installed start to finish AES-128 encryption of information guaranteeing ideal security and assurance and diminishes forthright framework speculations, just as working and end-hub costs.

3. Problem Formulation

Direction for the lighting of public roads, streets, and expressways is given in the Standard. Since these rules are not implemented by any administrative power, it is normal for regions to be uninformed of the guidelines, and many neglect to agree. The most widely recognized purposes behind wasteful road lighting frameworks in regions are:

- Poor design and installation.
- Selection of inefficient luminaries
- Poor power quality.
- Poor operation and maintenance practices.

4. Methodology

To satisfy the goal and do the equity in this exploration work an equipment arrangement will be introduced in appropriate premises for the showing. Streetlamp contains various sorts of the sensor will be incorporated like Light ward resistor (LDR) for sunshine saving, Passive infrared resistor (PIR)for movement recognition, LM35 for close to exact detecting temperature, MQ-7 for checking the contamination made via carbon monoxide and hydrogen, Arduino as a microcontroller, and ESP8266 for information move as appeared in figure 2.

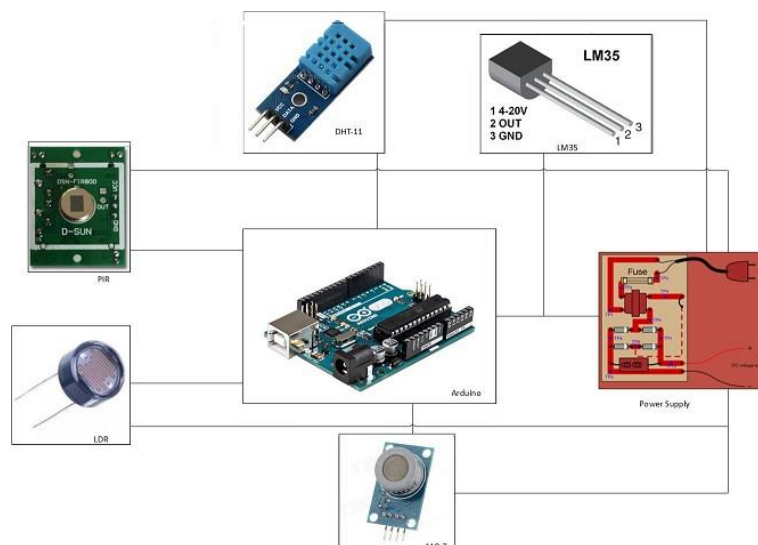

Fig.2. Sensor Box attach in Street Light

This figure is remembered for the container to join in streetlamp with various capacities to imagine and dissect it. The exhibition confine is showing the figure 3 that contain these things.

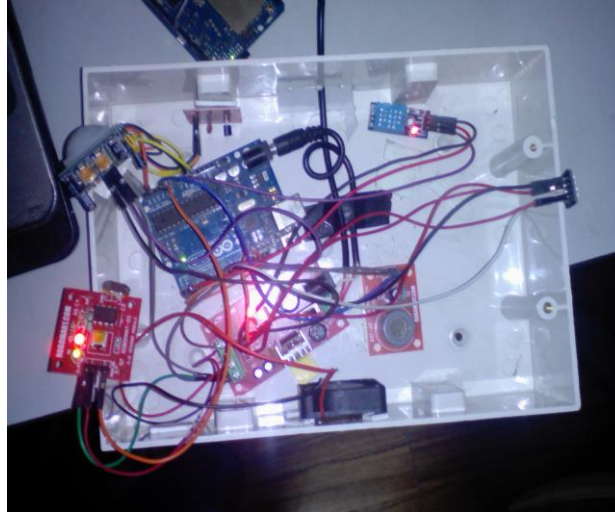

Fig.3. Demonstration Box that will be attached in street Light that contains sensor explained in above figure 2

The main model of this project is shown in the figure that explains how the project goes further process.

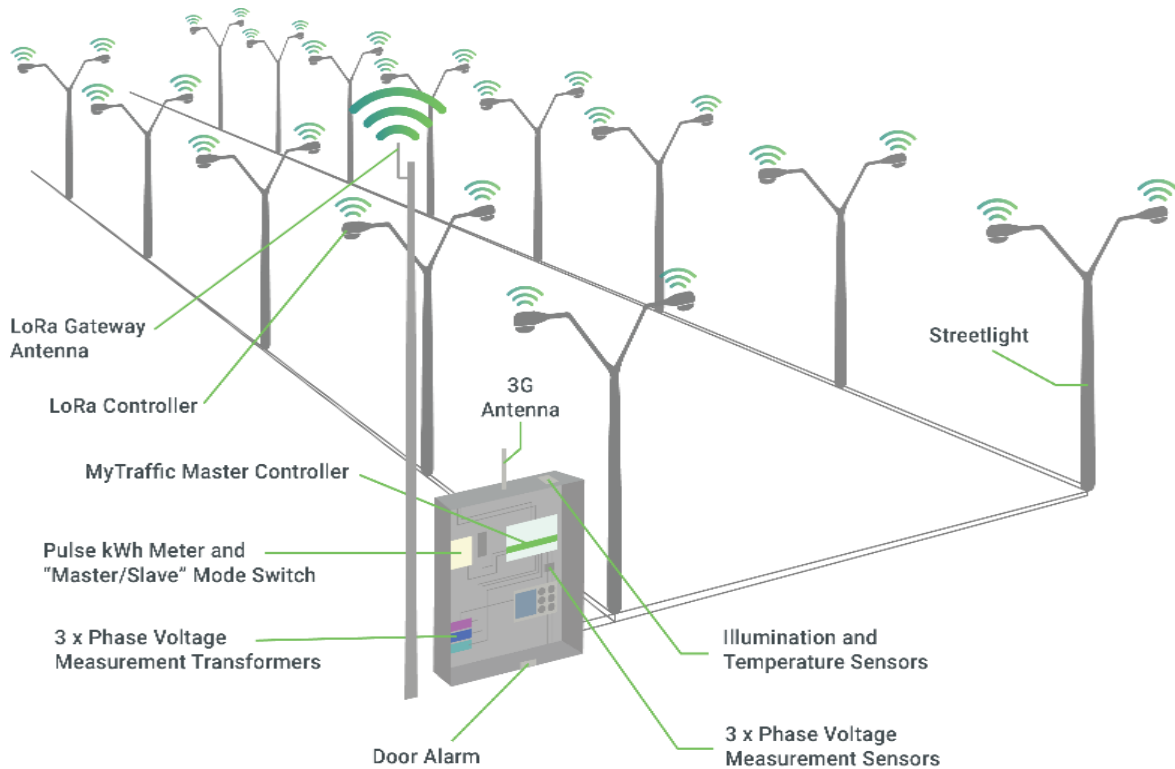

Fig.4. Proposed System Model

The Steps involved in this model

- Sensors embedded in each street light have the ability to control light functions
- LoRa Technology in the sensor connects the street light to a LoRa-based Gateway
- The LoRa gateway aggregates data from all nearby street lights
- Sensors for other smart city applications connect to the same gateway.
- The gateway sends information to the cloud where the data is analyzed by an application server
- Application server controls lighting
- The server sends maintenance alerts for burnt-out bulbs and other issues.

5. Results

The task has been begun with the amassing of the sensors as appeared in figure 3 from which the temperature, stickiness, and the condition of light through LDR has been gotten for additional outcomes will have the option to show are finished the establishment of a streetlamp inappropriate premises where the exhibition should be possible.

6. Conclusion

This research guarantee that this task will help in limiting the energy which is squandered in the streetlamp. It will have mechanized by the prerequisite of street and vehicle in the street with significant data will be introduced in the drove screen present in the shafts at specific spots. This paper portrays how the minimization of work is decreased just as eliminating the manual observation of the shafts. This would have the option to identify the defective light present in the shafts and would make them ready to utilize common assets.

References

- [1] Shahzad G., Yang H., Waheed A., Lee C. "Energy Efficient Intelligent Street Lighting System Using Traffic Adaptive Control", IEEE Sensors Journal, DOI 10.1109/JSEN.2016.25.57345, 2015 IEEE.
- [2] Jin H., Jin S., Chen L., Cen S., Yuan K. "Research on The Lighting Performance of Led Street Lights With Different Color Temperatures", IEEE Photonics Journal, Vol 7, Number 6, December 2015.
- [3] Ding Q., Sun Bo, Zhang X. "A Traffic light aware Routing Protocol based on Street Connectivity for Urban Vehicular Ad hoc Networks", IEEE Communication Letters, DOI 10.1109/LCOMM.2016.2574708, 2016 IEEE.
- [4] Cheng C., Cheng H.-l., Chung T.- Y. "A Novel Single-Stage High-Power-Factor LED Street-Lighting Driver with Coupled Inductors", IEEE Transactions on Industry Applications, DOI 10.1109/TIA.2014.2304585, 2013 IEEE.
- [5] Camponogara D., Ferreira G.F., Campos A., Costa M. A. D., "Offline LED Driver for Street Lighting With an Optimized Cascade structure", IEEE Transactions on Industry Applications, Vol- 40, No-6, Nov/Dec 2013.
- [6] Lee H.-C., Huang H.-B., "A Low-Cost and Noninvasive System for The Measurement and Detection of Faulty Streetlights", IEEE Transaction on Instrumentation and Measurement, IEEE 2014.
- [7] Pinto M. F., Soares G. M., Mendonca T. R. F., Almeida P.S., Braga H A.C. "Smart Modules for Lighting System Applications and Power Quality Measurements", 2014 IEEE.

Authors' Profiles



Ashish Kumar Jha received his Master's degree in Computer Science Specialization in Networking from Sharda University in 2017. He has involved in software development and teaching profession since 2013, currently working as assistant professor in Nepal Engineering College. His research interest includes, Internet of Things, Image Processing and pattern Recognition.



Menuka Maharjan is assistant professor at Department of Computer Science and Engineering, Nepal Engineering College. She holds M. E. in computer Science from Nepal College of Information Technology, Pokhara University. She has been in the teaching field since the last 8 years. Her research interest includes data science and machine learning.

How to cite this paper: Ashish Jha, Menuka Maharjan, " Smart Lighting System Using LoRa WAN Technology ", International Journal of Engineering and Manufacturing (IJEM), Vol.12, No.1, pp. 48-53, 2022. DOI: 10.5815/ijem.2022.01.05